

# INNOVATION FRUGALE:

## Faire Mieux Avec Moins

**Navi Radjou**

*Conseiller en innovation et leadership (Silicon Valley)*

*Co-auteur de L'Innovation Jugaad et Le Guide de l'Innovation Frugale*

# INNOVATION FRUGALE: LE SAVOIR-ETRE



**FAIRE MIEUX  
AVEC MOINS**



**AVOIR** Moins # **ETRE** Moindre







**LESS  
IS  
MORE**



# Rareté de ressources = opportunité pour innover

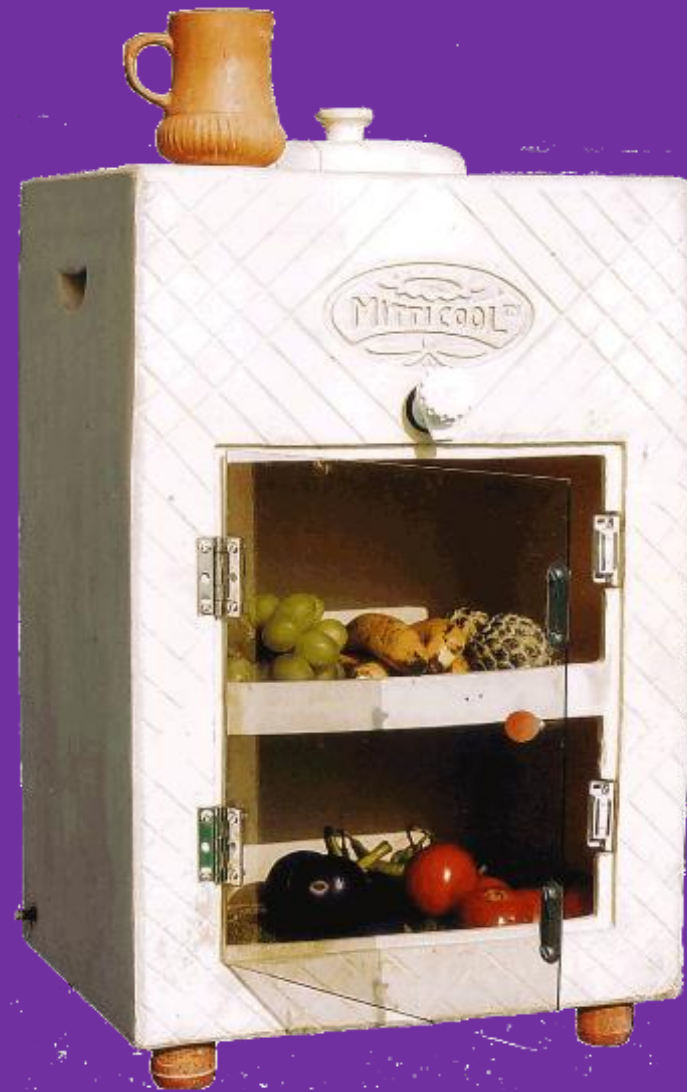





**\$20,000**

Bundesarchiv, Bild 183-1089-0712-025  
Foto: Roeske, Robert | 12. Juli 1989



**\$200**





+ 300,000 bébés sauvés !



Photo: EMBRACE





**Harish Hande, Ph.D.**  
Fondateur, SELCO



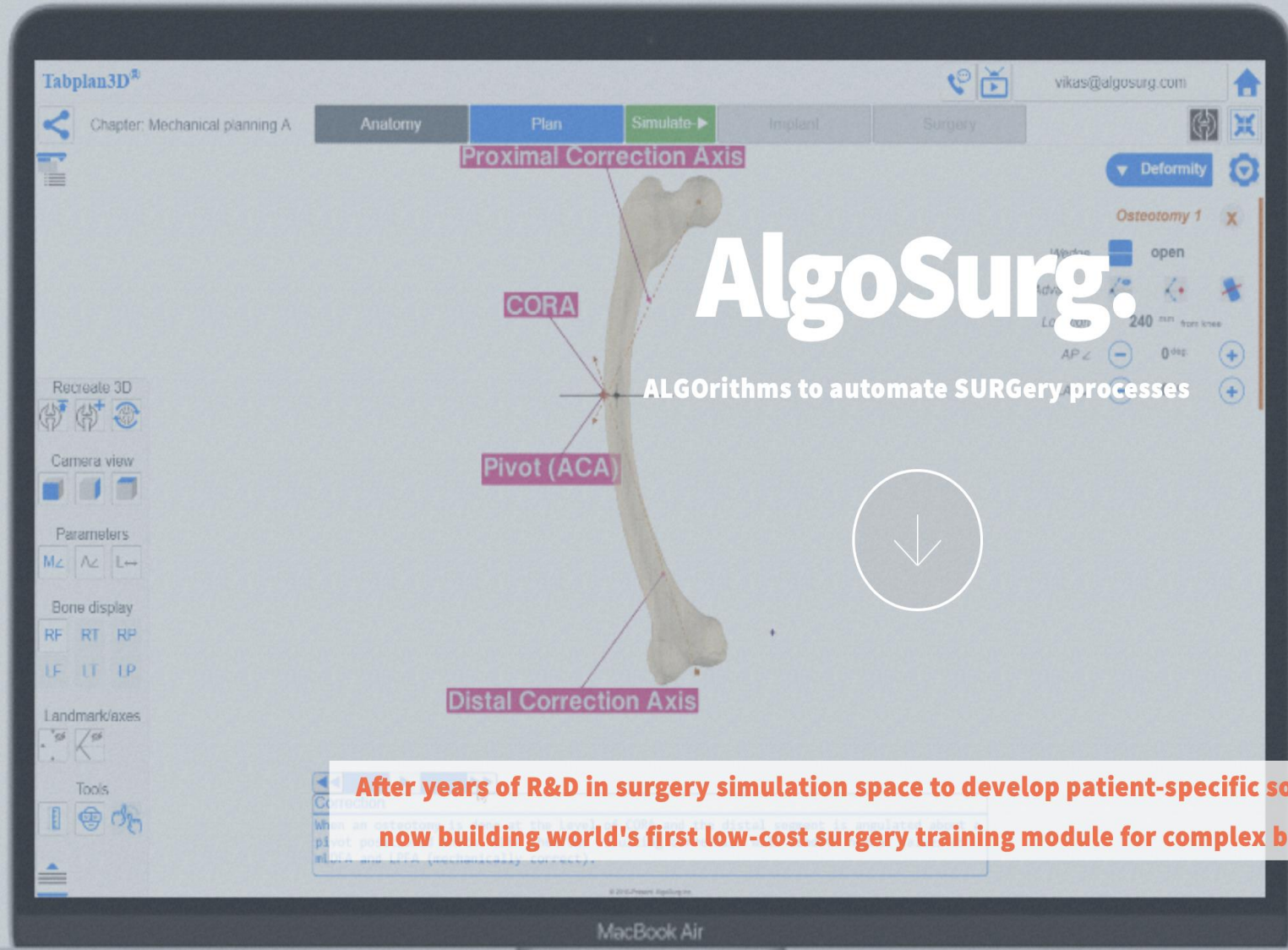

**After years of R&D in surgery simulation space to develop patient-specific solutions, we are now building world's first low-cost surgery training module for complex bone surgeries**

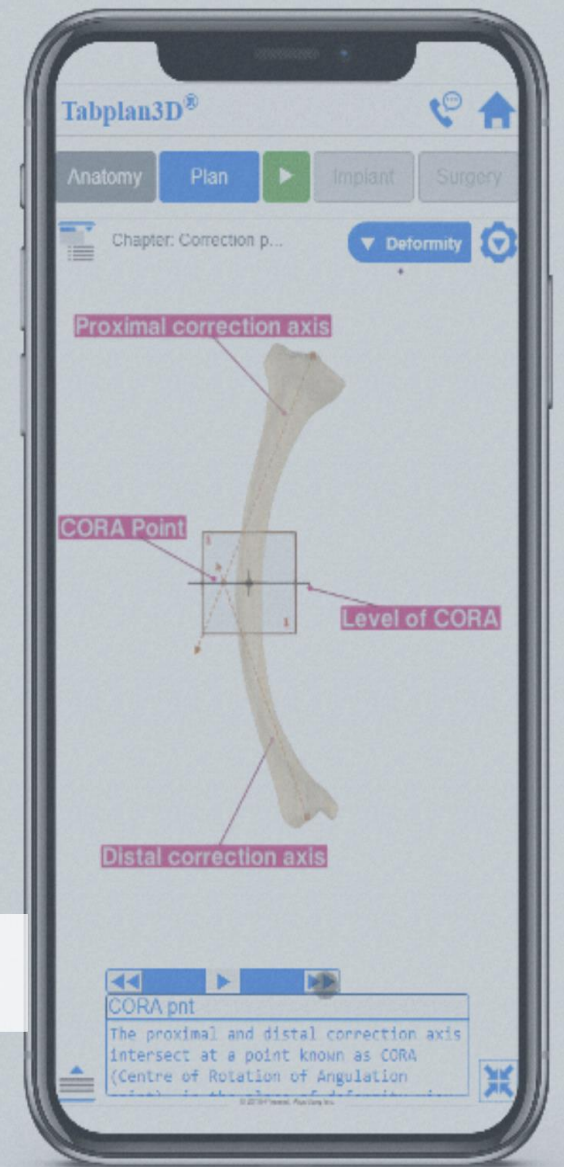



# India's Mangalyaan

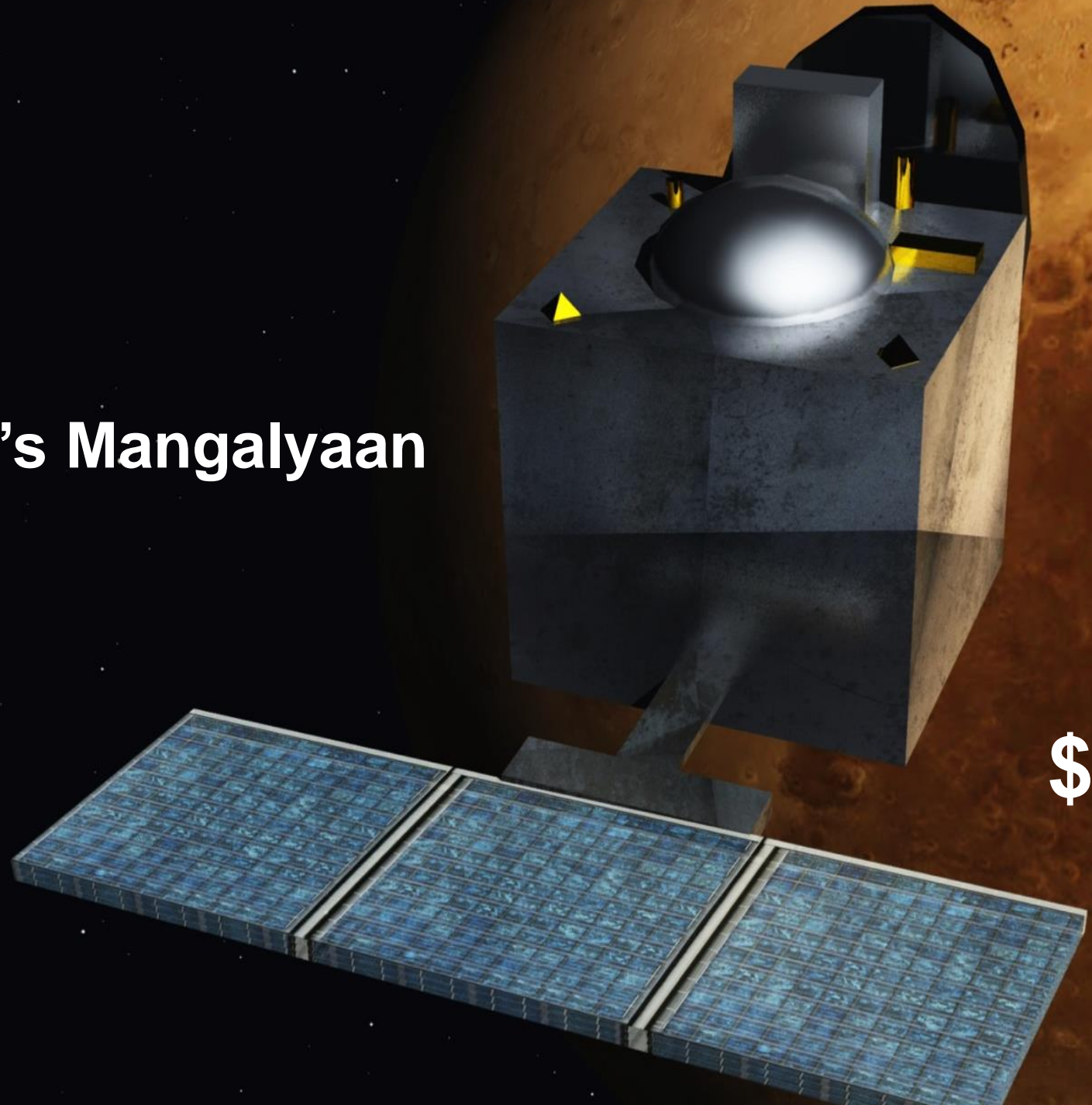

**\$74 millions**



The image shows the MAVEN (Mars Atmosphere and Volatile EvolutioN) spacecraft in orbit around Mars. The satellite is a rectangular box with a large, silver, dome-shaped antenna on top. It has two large, blue, rectangular solar panel arrays extending from the sides. The background is the reddish-orange surface of Mars, with a thin white atmosphere visible at the horizon. The text "NASA's MAVEN" is overlaid in white, bold, sans-serif font on the left side of the image.

**NASA's MAVEN**

**\$671 millions**



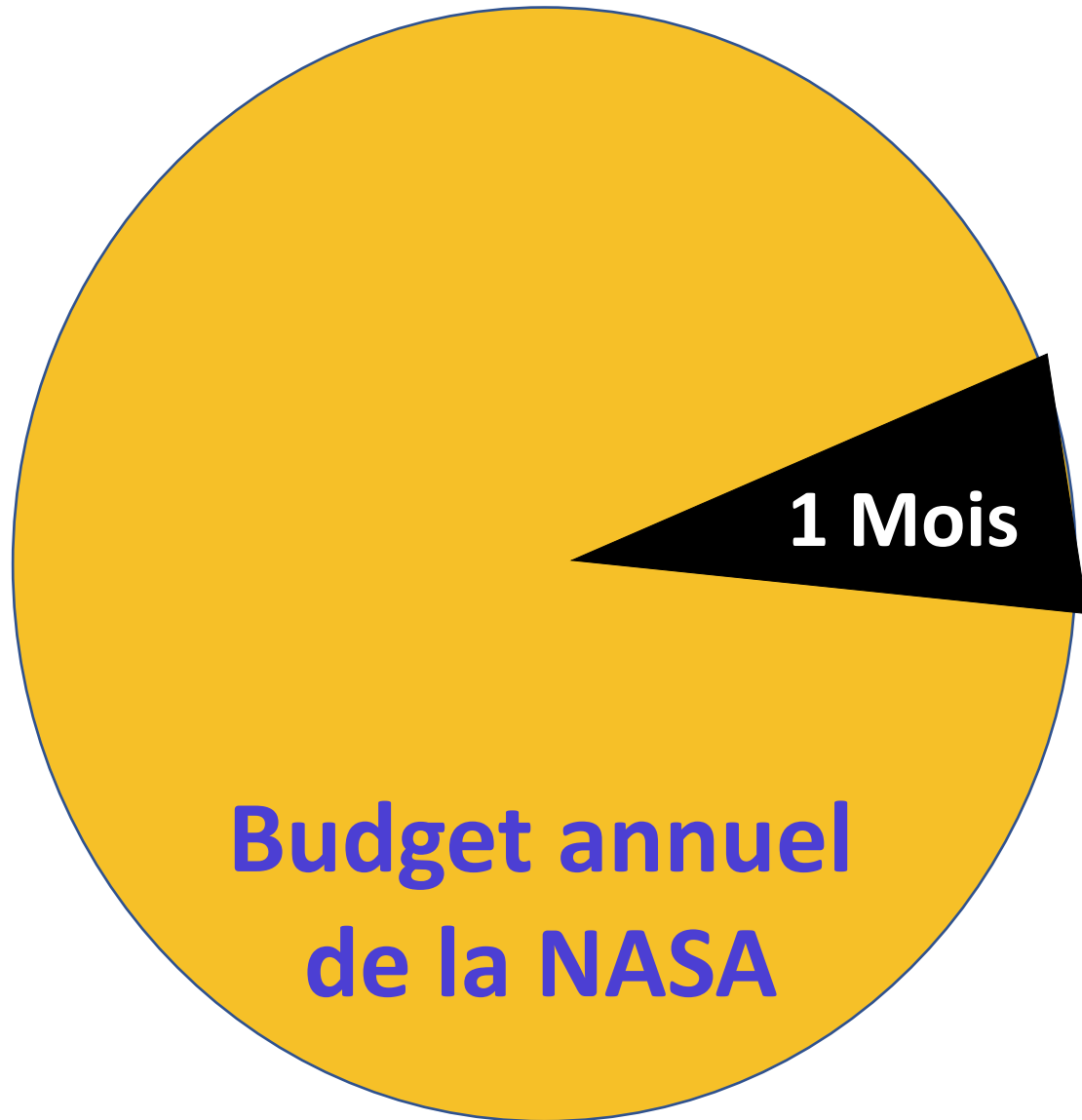

**Budget annuel  
de la NASA**

**1 Mois**

**Budget  
annuel  
de l'agence  
spatiale  
indienne**





Chercheurs du CSIR  
(equivalent du CNRS)

€ 6



**INDIA'S FIRST  
CRISPR PAPER  
STRIP TEST FOR  
COVID-19**



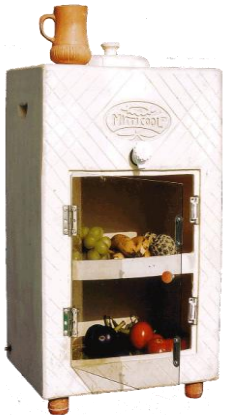

**Solutions  
Ingénieuses**

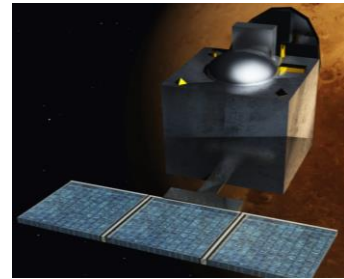

**Modèles  
Economiques  
Frugaux**

**JUGAAD**



Navi RADJOU, Jaideep PRABHU & Simone AHUJA

# L'INNOVATION



# JUGAAD

REDEVENONS INGÉNIEUX !

Traduction et adaptation : Jean-Joseph BOILLOT

*diateino*



**Je n'ai pas X**

**J'ai Y**





**Ressources tangibles:**

- Eau
- Energie
- Argent

**Ressources intangibles:**

- Ingéniosité
- Empathie
- Résilience
  
- Connaissances traditionnelles
- Capital social

**RE-SOURCE**

**RE-SOURCE**

# INNOVATION FRUGALE: LE SAVOIR-FAIRE





**22%**

**Population UE  
en risque de  
pauvreté**

**60%**

**Americains  
n'ont pas \$500  
d'épargne**





**THUNBERG**



# Le FMI revoit encore les prévisions de croissance mondiale

CROISSANCE DE L'ÉCONOMIE MONDIALE

**-4,9%**

à la baisse, au plus bas niveau  
depuis la Grande Dépression

# L'innovation frugale

↑ **VALEUR(S)**



↓ **RESSOURCES**

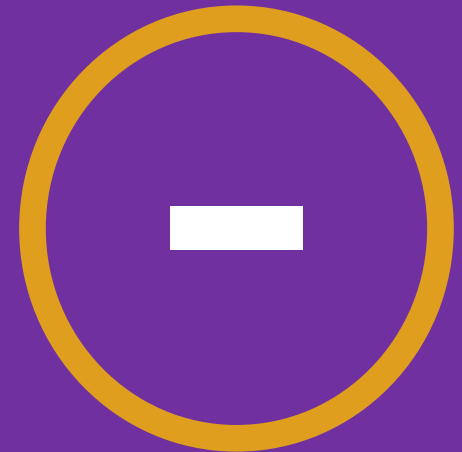



# L'innovation frugale: Faire MIEUX avec MOINS

↑ **VALEUR(S)**

- Economique
- Sociale
- Ecologique

↓ **RESSOURCES**

- Capital
- Energie
- Temps

« Fascinant » - *Financial Times*

NAVI RADJOU ET JAIDEEP PRABHU

# LE GUIDE DE L'INNOVATION FRUGALE

**LES 6 PRINCIPES CLÉS  
POUR FAIRE MIEUX AVEC MOINS**



PAR LES AUTEURS DU BEST-SELLER *L'INNOVATION JUGAAD*

*diateino*



# LES 6 PRINCIPES DE L'INNOVATION FRUGALE

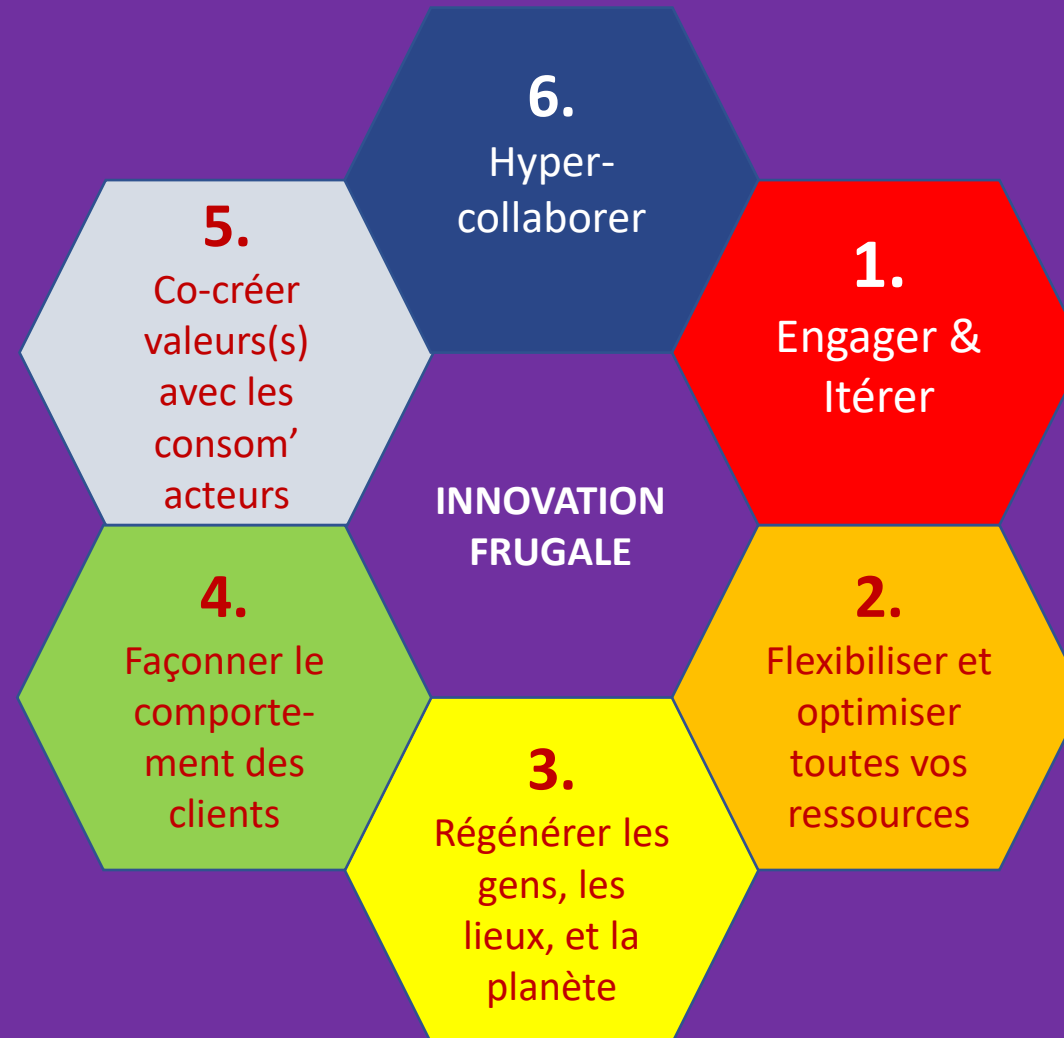

# Principe #2: Flexibiliser et optimiser toutes vos ressources







**Je n'ai pas X**



**J'ai Y**





**ELECTRICITE**



**LUMIERE  
AMBIANTE**







**LIGHT  
AS  
YOUR  
ENERGETIC  
RESPONSE**

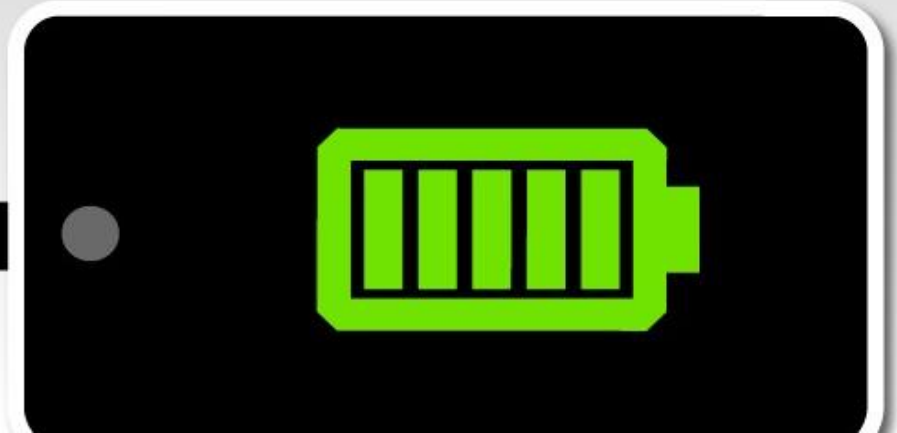







**DÉSERTS  
MÉDICAUX**



**MÉDECINS  
SOUS-UTILISÉS**

**Téléconsultez simplement,  
rapidement, avec ou sans  
rendez-vous !**

Avec Hellocare, souriez, vous êtes soigné !

### Consulter mon médecin traitant en ligne

- Rendez-vous en ligne
- Sans déplacement
- Selon vos disponibilités
  - Remboursé \*

AVEC RDV

Votre médecin n'est pas inscrit ?



Mathilde Le Rouzic et William Benichou





**RESPIRATEURS**



**MASQUES  
DE PLONGEE**



Soyez **agile** : Posez-vous la question “**POURQUOI PAS?**”



DECATHLON





Letture di Favero e Fracassi, ecco i Cavalieri bresciani

# ecco i Cavalieri bresciani



Renato Favero e Cristian Fracassi con la maschera da snorkeling modificata

Tutto Schermo

**Légion d'Honneur  
en Italie  
pour le Système D**





**MASQUES &  
ECRANS  
FACIAUX**

**JEUNE TALENT**



# FIGHTING COVID-19

**1,073,704**

M-19 shipped of  
**1,000,000** goal

DONATE FOR MAKER'S ASYLUM

DONATE FOR JAIPUR

DONATE FOR DELHI

DONATE FOR GANGANAGAR

DONATE FOR NAGPUR

DONATE FOR PUNE

M19 Shields Given

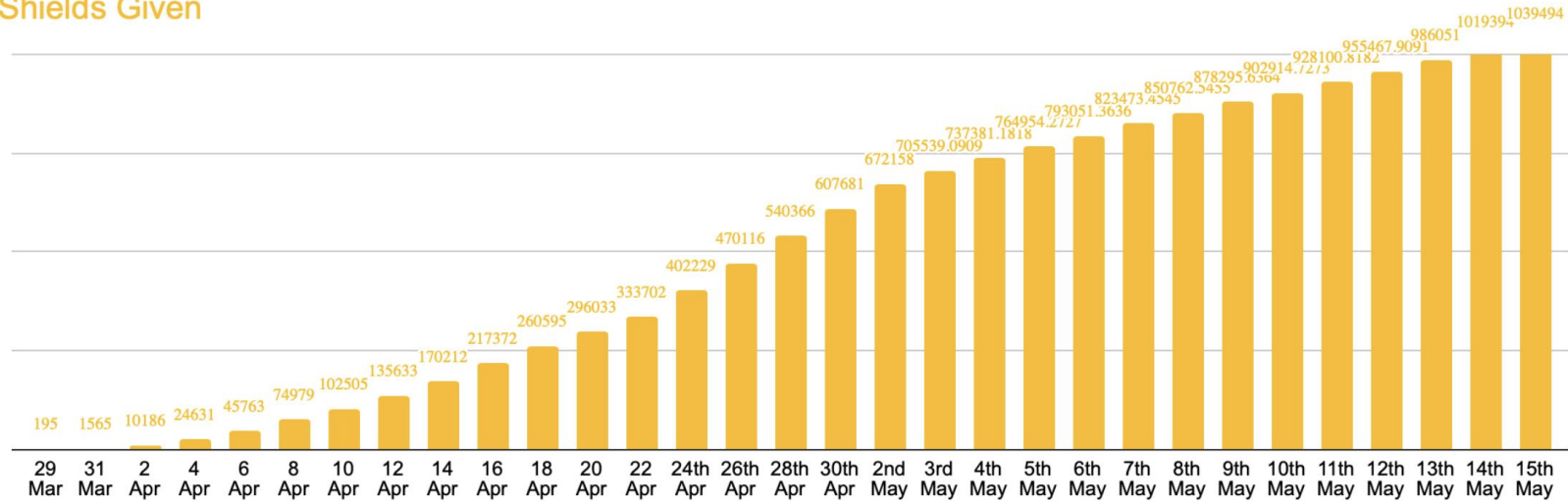

# Collectif Frigal par madNess

Un collectif d'innovation frugal fondé par madNess.

En s'appuyant sur des principes simples et des moyens très modestes, il a réalisé en moins de deux mois :

- La fabrication frugale,
- L'industrialisation des masques visières,
- La réparation des machines respiratoires et médicales du parc hospitalier de Casablanca,
- La fabrication de sa propre machine respiratoire,
- La sensibilisation de plus de 3 millions et demi de personnes sur les réseaux sociaux,
- La fabrication de plusieurs dispositifs et l'industrialisation de ceux ci.

La créativité et l'innovation  
au service de l'impact social.

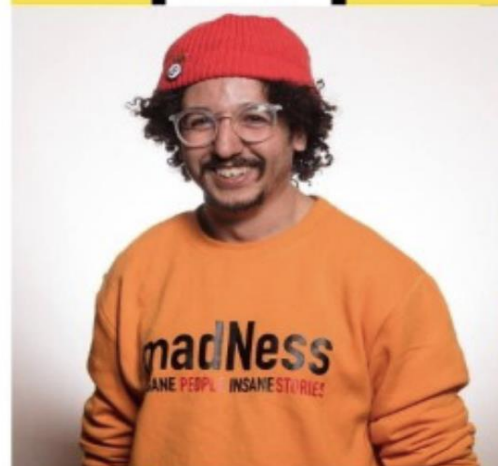

**madNess**  
INSANE PEOPLE INSANE STORIES

**FRIGAL**  
INNOVATION AND CREATIVITY  
COLLECTIVE FOR COMMON GOOD





**COMPTES  
BANCAIRES**

**BURALISTES**

AU  
TE  
QUE

COMPTE  
**NICKEL**  
Le compte sans banque



**COMPTE NICKEL: LA BANQUE SANS UNE BANQUE**



**5**  
minutes

**€20** frais

**5,500**  
buralistes

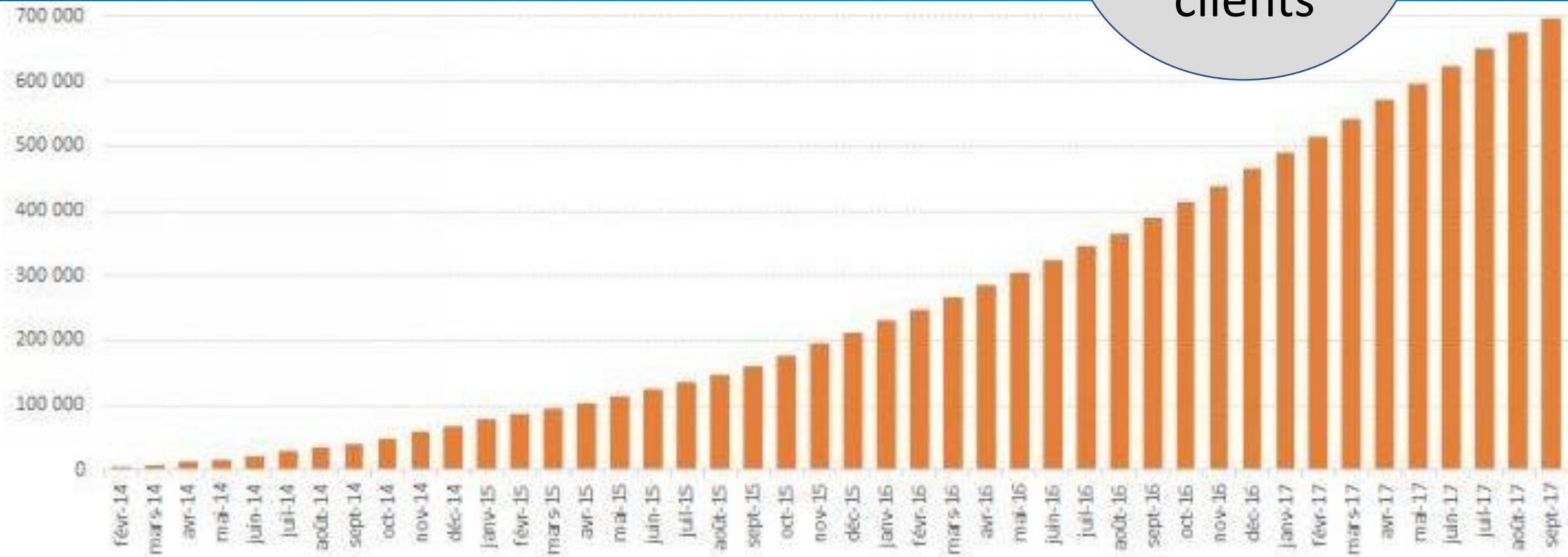

Photo: Ouest France



Un nouveau compte ouvert toutes les 5 minutes !

**1.5  
millions  
clients**





## RESSOURCES TANGIBLES:

- Argent
- Matériel
- Personnel



## RESSOURCES INTANGIBLES

- Ingéniosité
- Empathie
- Résilience
- Capital intellectuel
- Capital social
- Technologies existantes
- Diversité des talents



# DISCUSSION

# Principe #3: Régénérer les gens, les lieux et la planète





# L'innovation frugale: Faire MIEUX avec MOINS

↑ **VALEUR(S)**

- Economique
- Sociale
- Ecologique

↓ **RESSOURCES**

- Capital
- Energie
- Temps

# Durabilité: FAIRE MOINS DE MAL

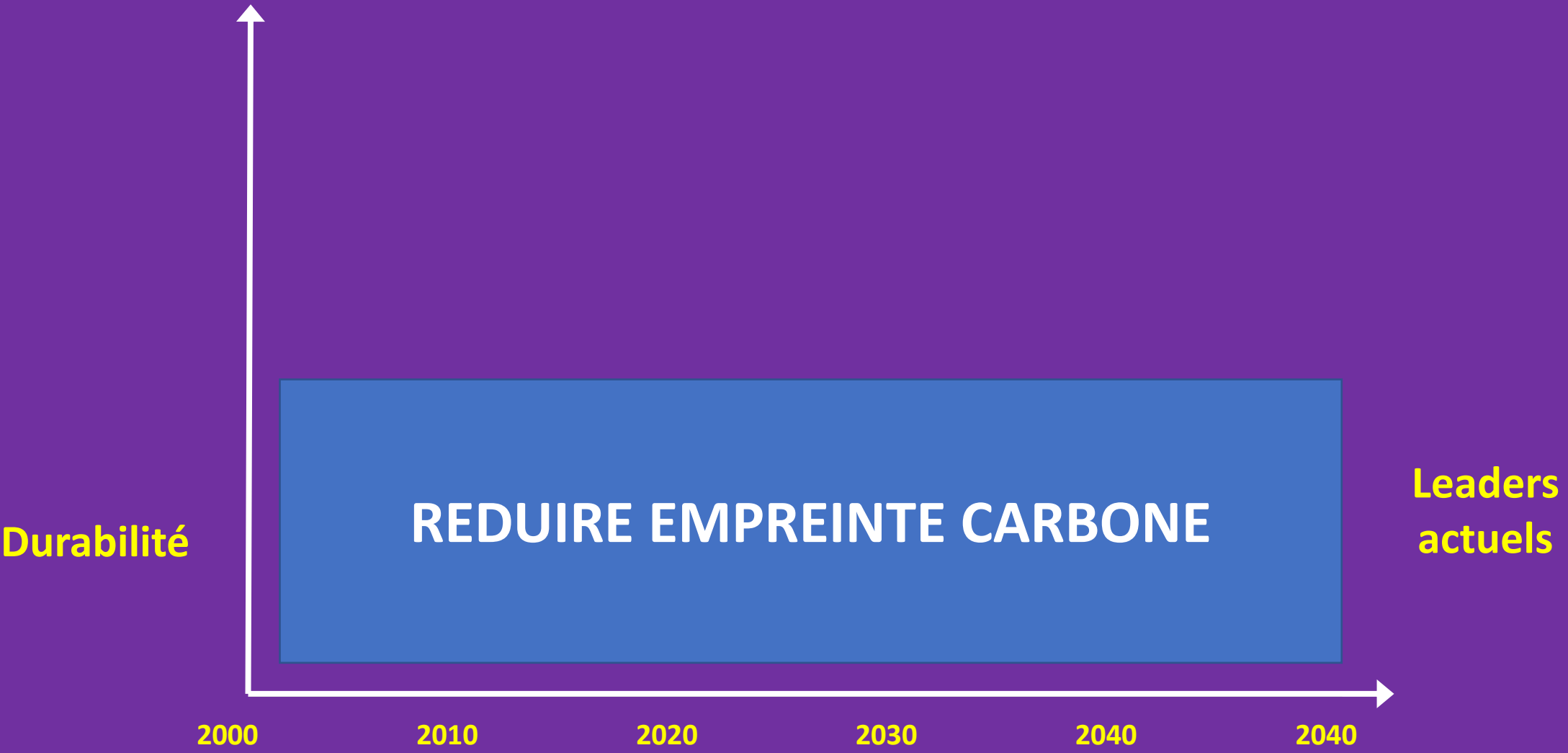

# Régénération: FAIRE PLUS DE BIEN

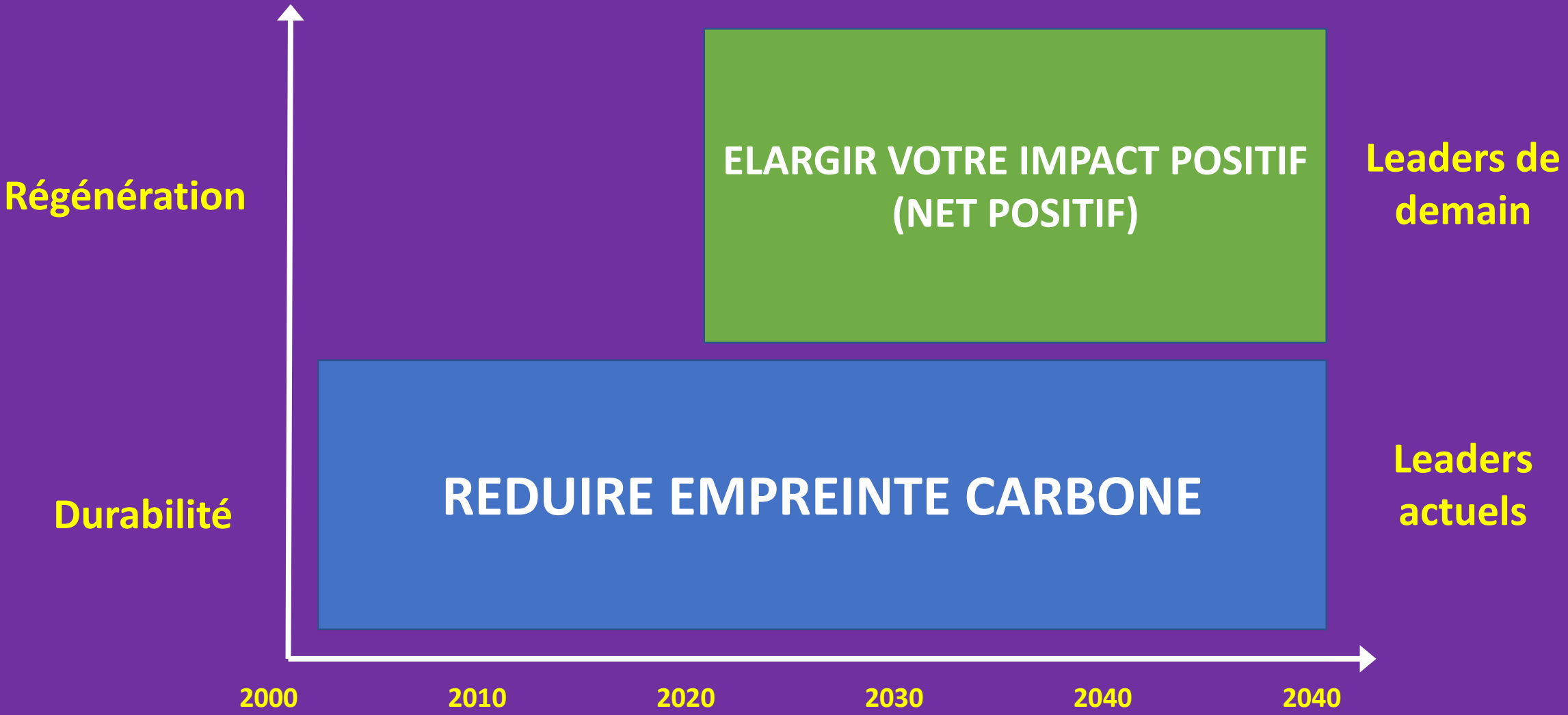



# Au delà de durabilité: vers une entreprise « **régénératrice** »

Landmark Research Study

ReGenForTheNextGen™  
NATIONAL CONSUMER RESEARCH REPORT

## THE EMERGING REGENERATIVE CUSTOMER

What They Think, How They Feel,  
& What They're Urging Companies To Do Next

“*Now that I understand what regenerative businesses offer and have seen the example of regenerative agriculture, it shows me that they do more than just promote the "good" of their business, but they also try to have a lasting effect on the planet as a whole, not just to even out the effects of their business.*”  
— February 24th 2019 (verbatim customer response)

Whole Health Marketing™  
by WHOLE HEALTH MARKETING™  
in partnership with ReGenFriends™

ReGen FRIENDS™

Copyright © 2019 Whole Health Marketing. Confidential and proprietary. Do not distribute without permission.

**80%**  
consommateurs  
préfèrent  
“**régénération**”  
plutôt que  
“**durabilité**”



# Devenir une « Entreprise comme Nature » (**Business-As-Nature**)

**Interface**<sup>®</sup>



**Usine comme Forêt**



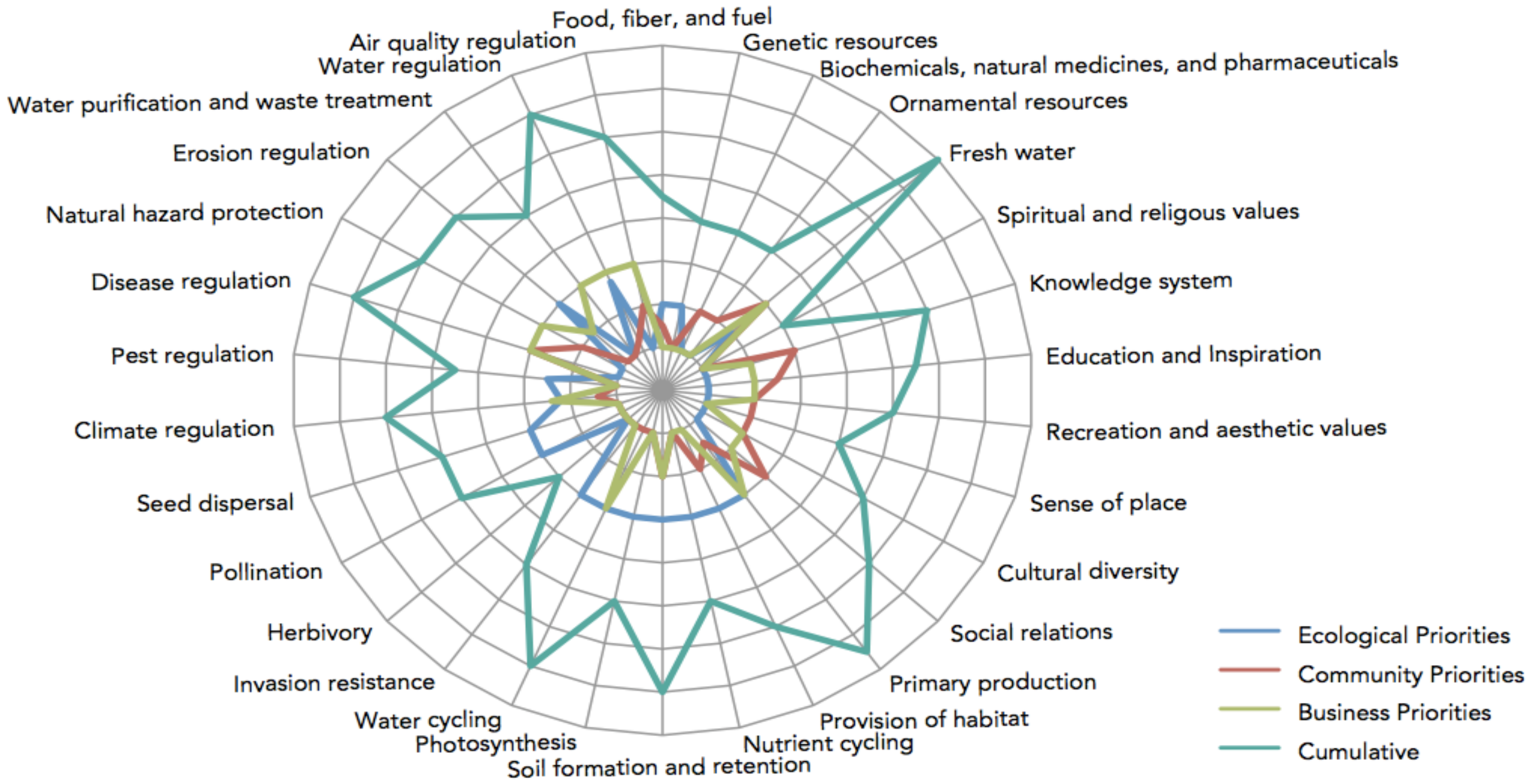



# MADE IN FRANCE

(économie linéaire  
hyper-globalisée)

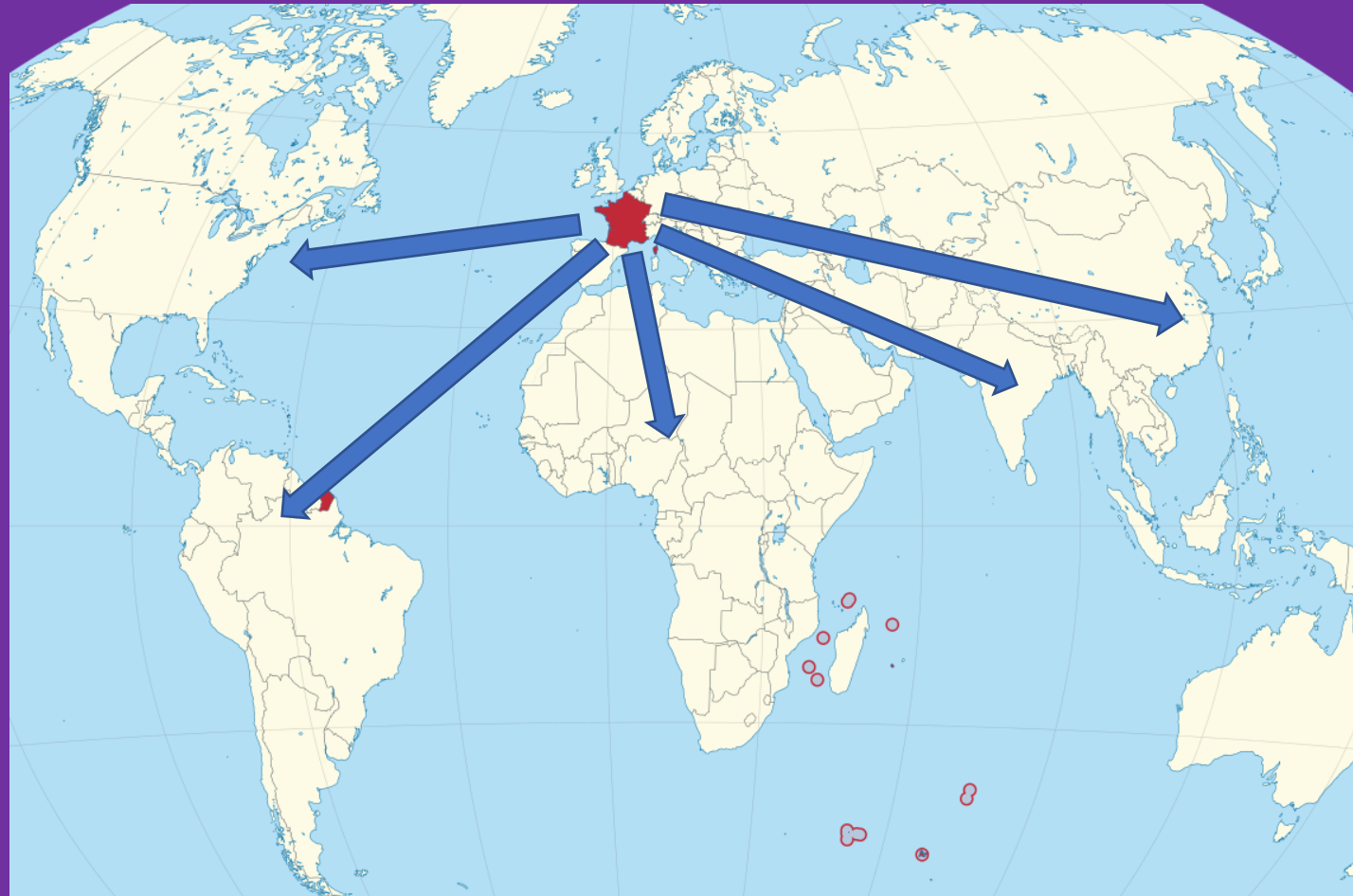

# RE-MADE IN FRANCE

(économie circulaire  
hyper-locale)

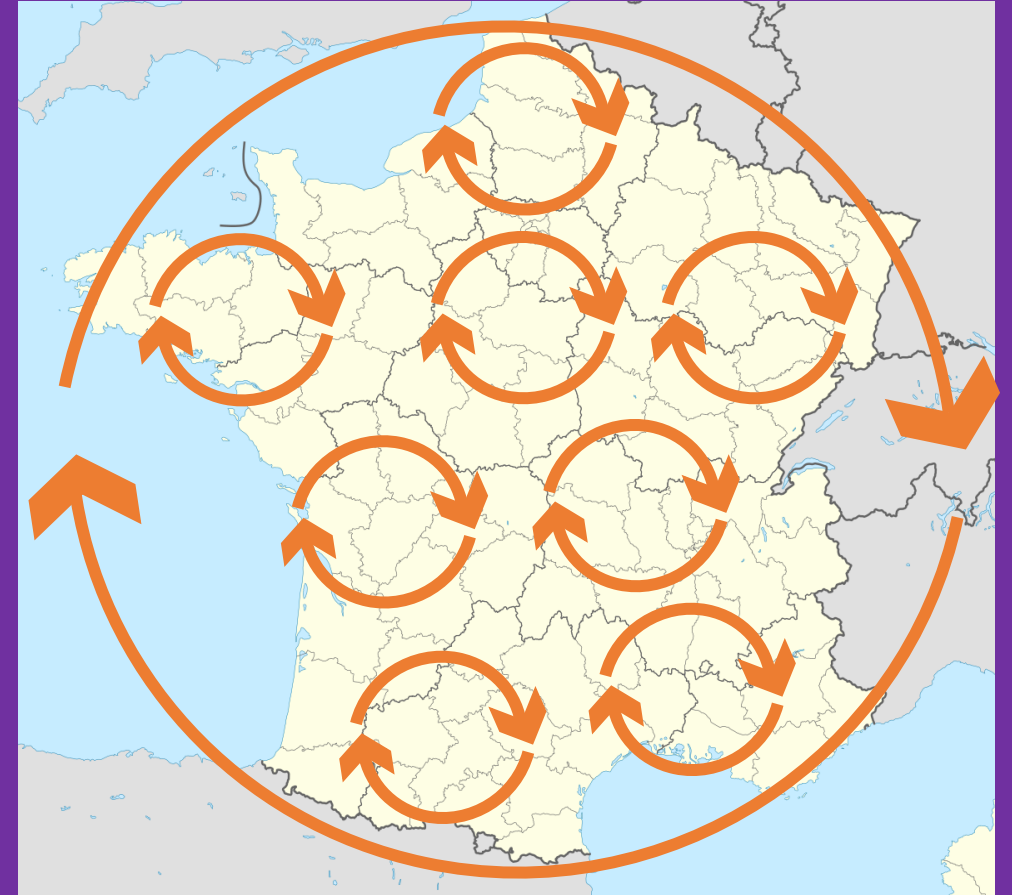



FEMME HOMME JEANS CHAUSSURES LE PROJET BLOG



## TRANSPARENCE = CONFIANCE

100% DES JEANS 1083 SONT EN COTON BIOLOGIQUE OU EN FIBRES RECYCLÉES.  
GRÂCE À LA RELOCALISATION DE TOUTES LES ÉTAPES DE FABRICATION,  
VOUS SAVEZ OÙ SONT FILÉS + TEINTS + TISSÉS + COUPÉS + COUSUS VOS JEANS 1083.



**Thomas Huriez**



# Intégrer “sociabilité” et ”durabilité”: La Poste

recygo

suez







**Rimagined.com**

**Shailaja Rangarajan**

Pionnière de l'économie régénératrice





**Ne  
gaspillons  
pas  
le talent  
humain**

# Au-delà de l'Économie Circulaire: Co-construisons une économie régénératrice





# Principe #4: Façonner le comportement des consommateurs



20eme siècle: “Je Consomme, Donc Je Suis”

21eme siècle: “Je Crée, Donc Je Suis”





Hortense Sauvard



APPRENONS LES UNS DES AUTRES

OUI ARE MAKERS



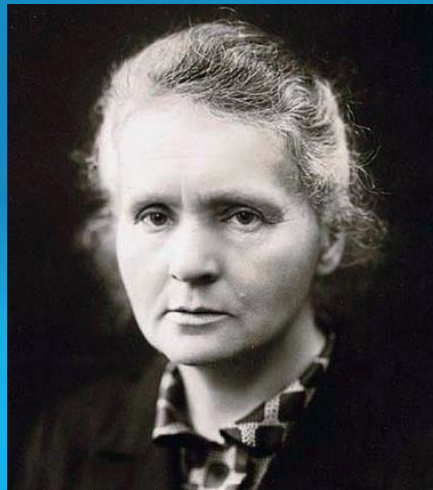
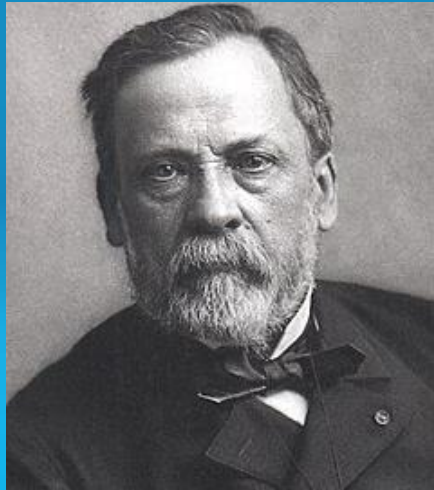





**\$1,000**



**\$1**

Microscope (Foldscope)



Prof Manu Prakash  
(Stanford University)



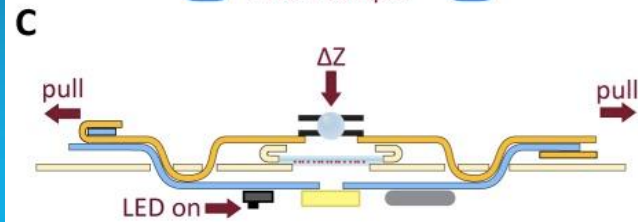
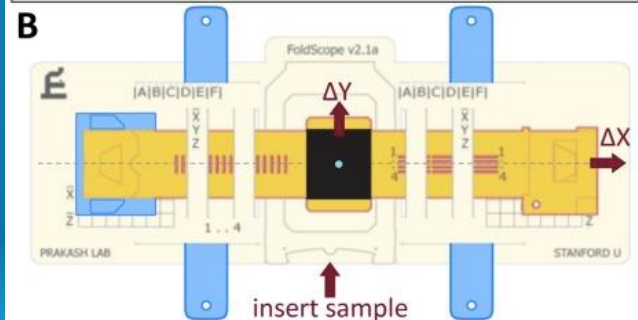
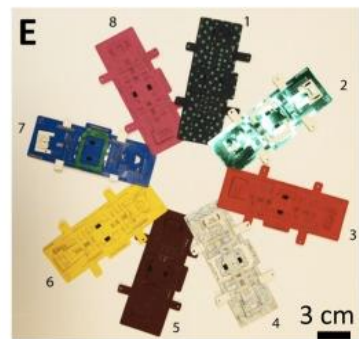
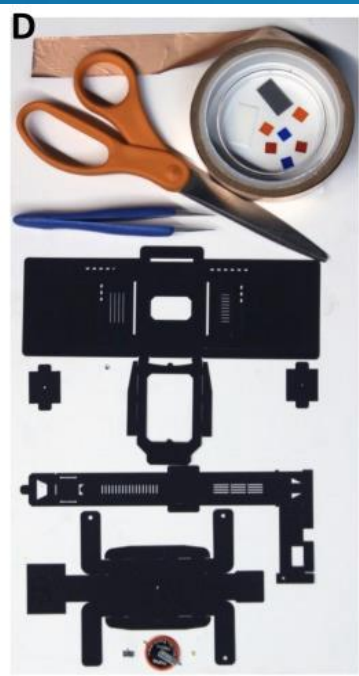
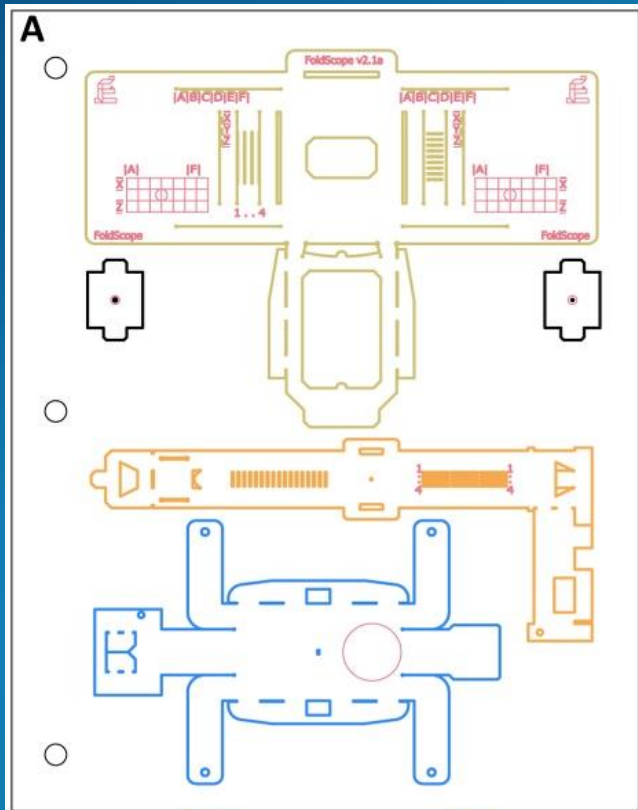

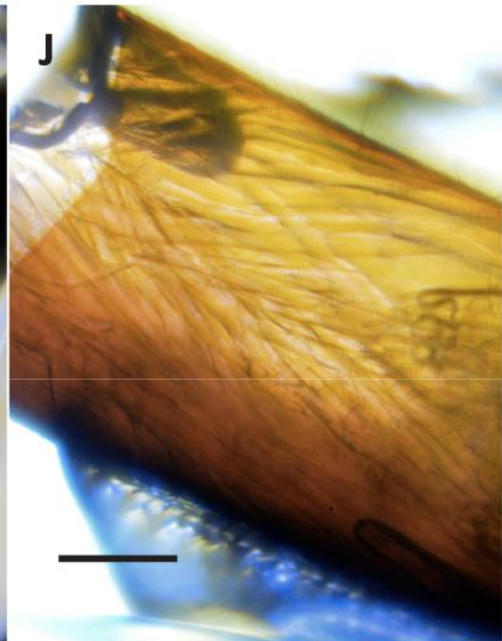
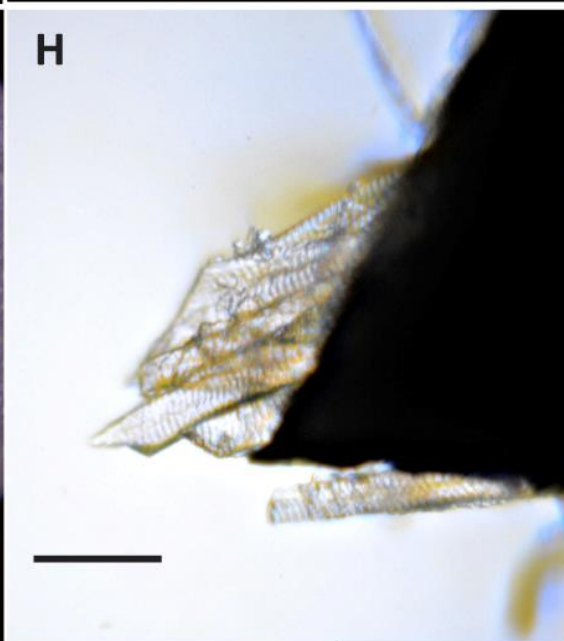
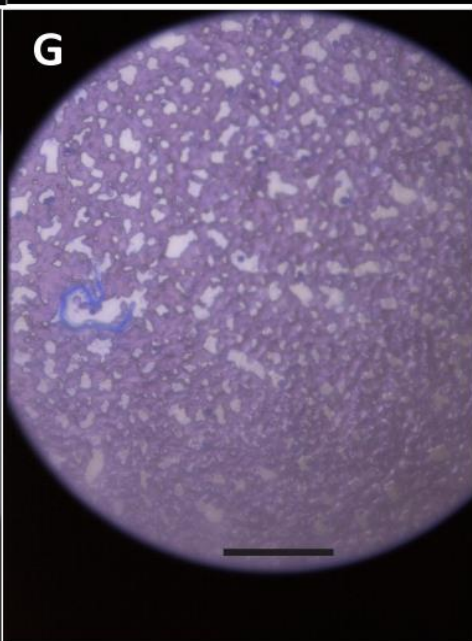
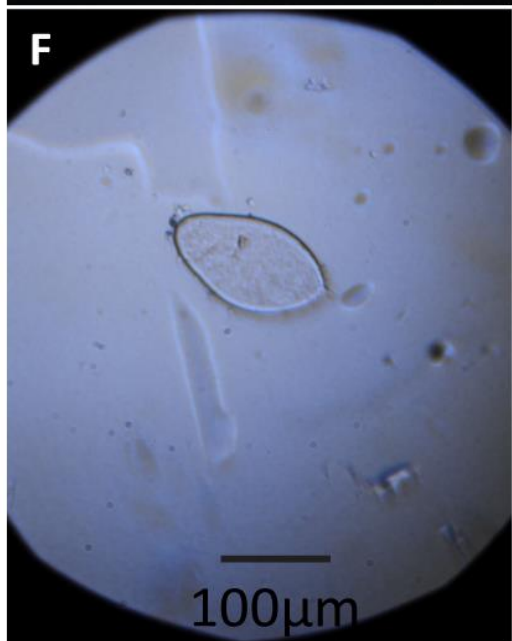
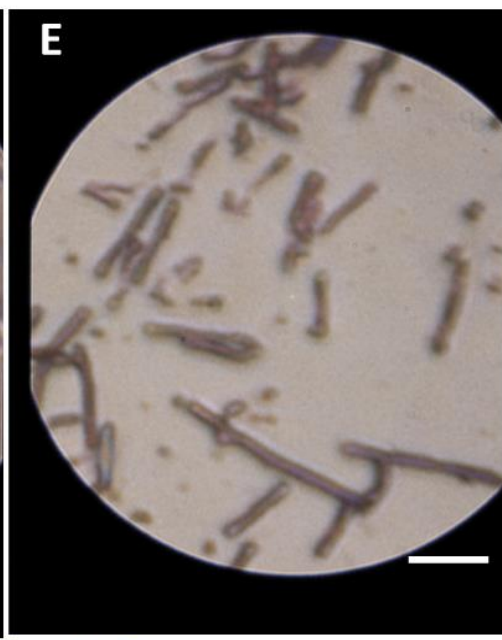
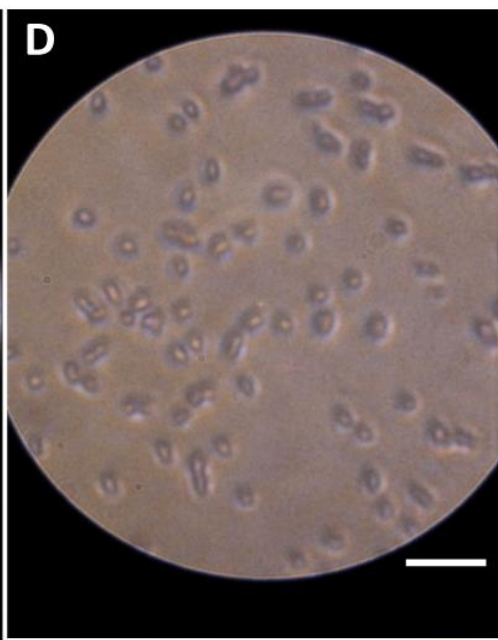
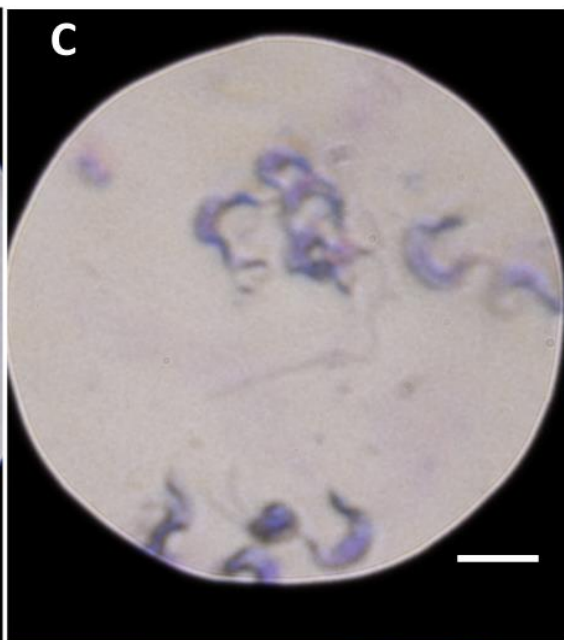
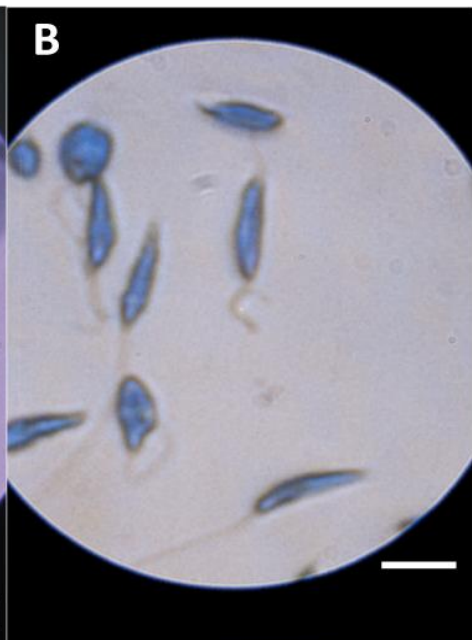



## Ecole Masai au Kenya



Devenons tous des “citizen scientists” (scientifiques citoyens)



**MAYOTTE**

**TERRE des  
MAKERS**



# Principe #6: Hyper-collaborer avec des partenaires « atypiques »



Pour avoir plus d'impact, jouez des rôles  multiples  dans les **réseaux d'innovation locaux/régionaux**

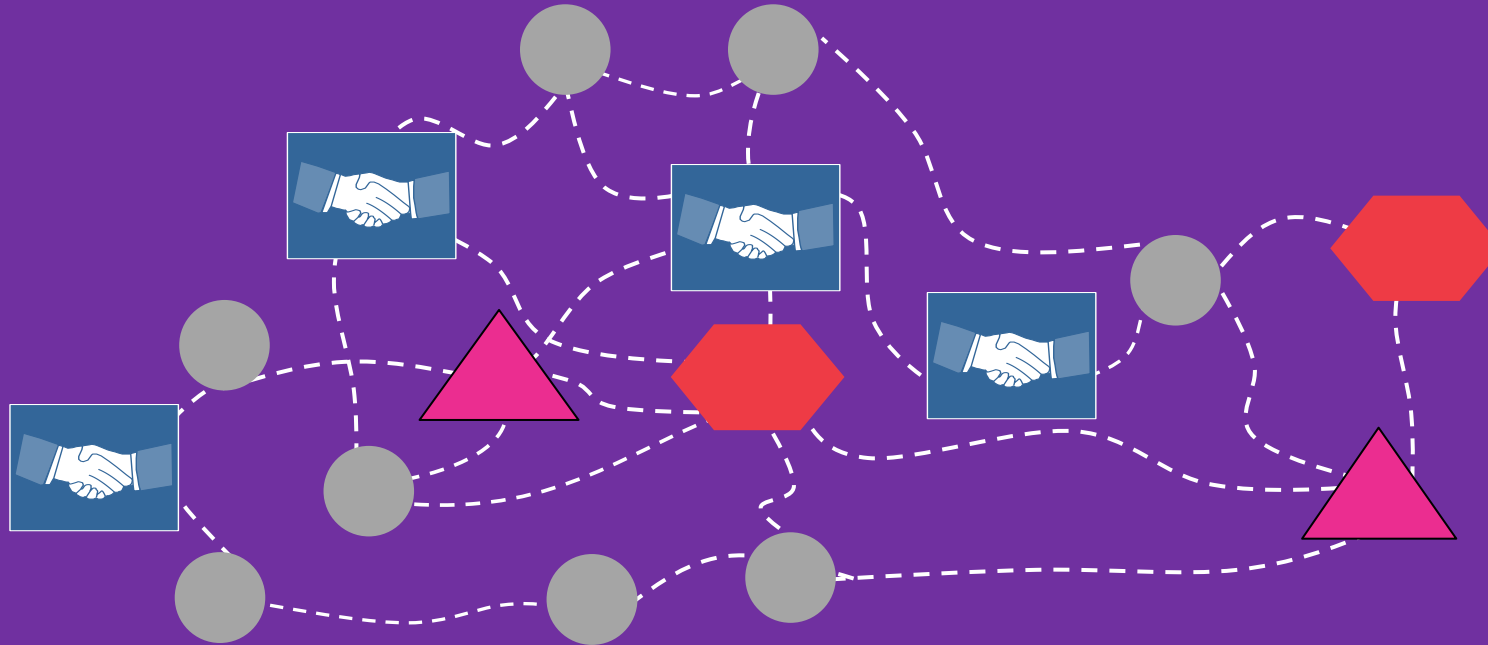

Inventeur



Transformateur



Financier



Connecteur



Pour avoir plus d'impact, jouez des rôles multiples  
dans les **réseaux d'innovation locaux/régionaux**

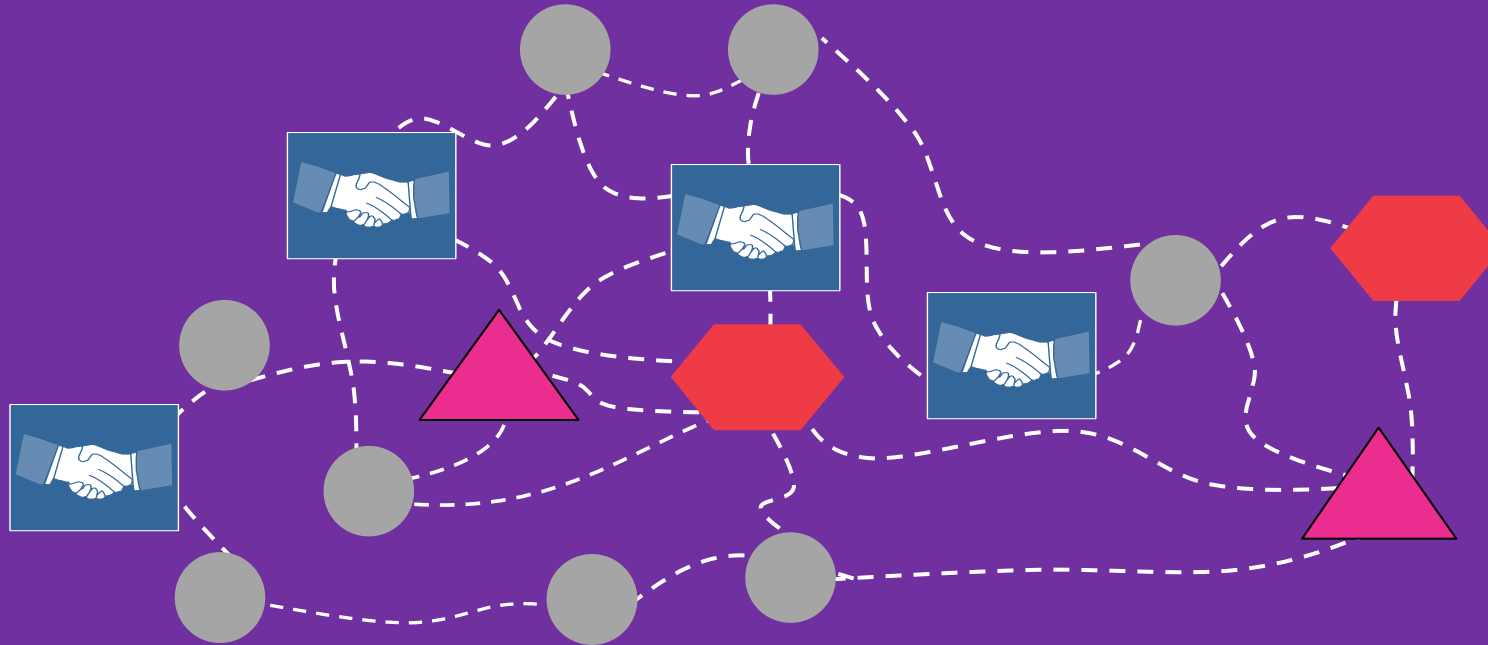

Inventeur



Transformateur

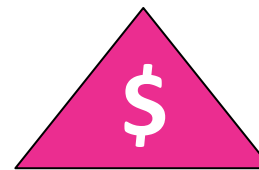

Financier



Connecteur

Pour avoir plus d'impact, jouez des rôles multiples  
dans les **réseaux d'innovation locaux/régionaux**

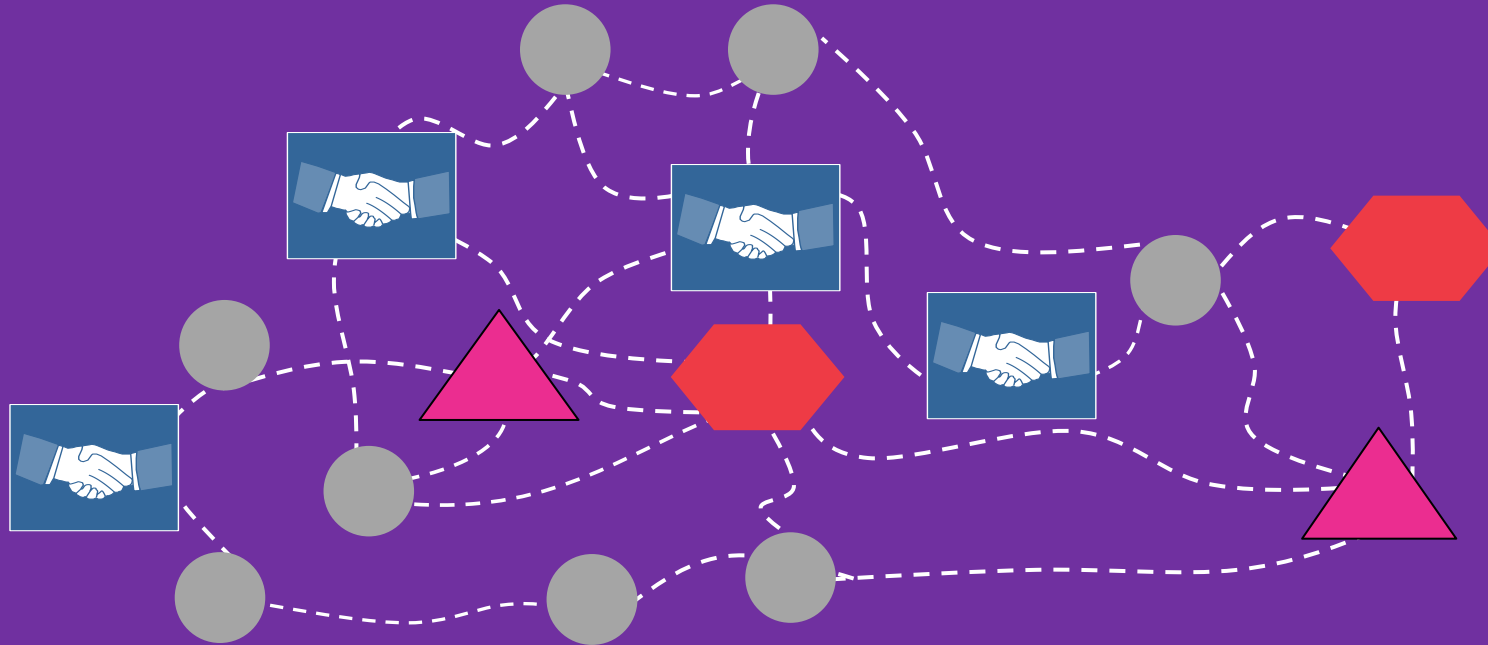

**Inventeur**



**Transformateur**



**Financier**



**Connecteur**





UN  
DP

Empowered lives.  
Resilient nations.

# Accelerator Labs

Building the world's largest and fastest learning network around development challenges.



UNDP is in 170 countries & territories investing  
**\$4.6 Billion In Development**

A global leader in development



**Ranked #1 In Value-For-Money<sup>1</sup>**

Because We Need To Re-Imagine  
Development For The 21st Century



# Building on Local Innovators

---

The Labs will identify grassroots solutions together with local actors and validate their potential to accelerate development. Solutions can come in many different forms, from a farmer discovering a new way to prevent floods to a nonprofit that is especially impactful.

The labs will also harness the potential of real time data and people's energy to respond to rapidly evolving challenges that impact development.

Building on these locally-sourced solutions, the labs will rapid test and iterate new ideas to learn which ones work, which ones can grow, and which ones don't, bringing experimentation to the core of our work.

## The Ability to Bridge to Scale

---

The labs will accelerate their learning by operating within a global network where each lab learns from the rest, by exploring multiple solutions in parallel, and by designing experiments that teach us whether solutions can work and grow in weeks or months rather than years.

Accelerator Labs will build on UNDP's partnerships with governments to scale solutions. Together with partners, they will try to learn what combination of solutions can influence how development is delivered. We'll also be exploring policy frameworks that are needed to frame the ethics and incentives to drive development acceleration and try to identify portfolios of solutions that could spin off into independent ventures.



## Quelques illustrations à Saint-Denis

- Un challenge innovation interne à l'entreprise municipale : les salariés ont créé eux mêmes un jackmat pour aider le personnel des écoles à soulever les matelas des enfants
- Un laboratoire d'innovation interne
- Une plateforme d'écoute sociale : système de travail social à distance pour permettre l'aide alimentaire aux plus vénérables pendant la crise du Covid
- La culture en numérique...
- Un atelier solidaire de découpe et de confection de 200 000 masques tissus .... Et où des hommes bénévoles s'assoient et cousent... de quoi tordre le cou à la théorie du genre...
- Un prototype « maison » de distributeur de gel et d'informations sur le covid 19 réalisé avec des matériaux de récupération.







Des nations  
construisent  
des murs...

...sans  
réaliser que...

...L'humanité est confrontée à des  
« problèmes sans frontières »

## WATER STRESS BY COUNTRY

ratio of withdrawals to supply

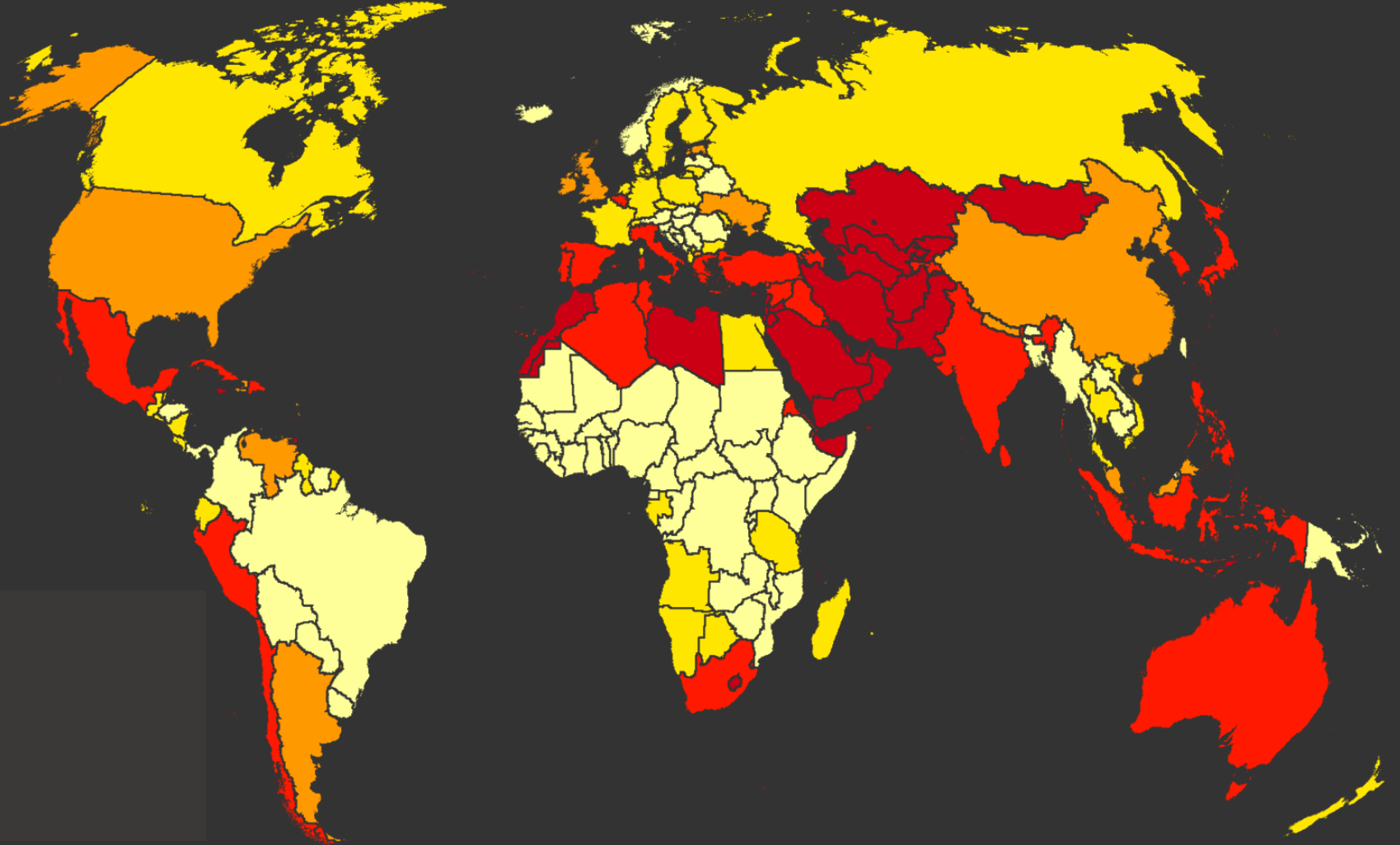
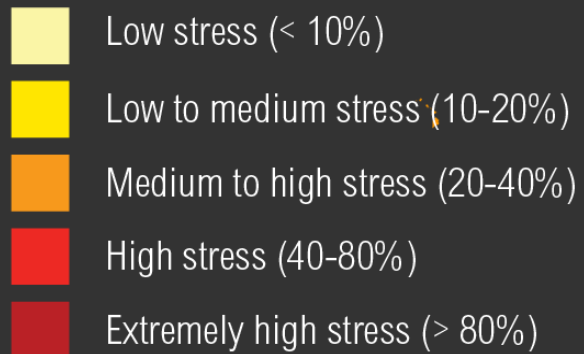



# Comment la France et l'Inde peuvent libérer le pouvoir de «l'innovation frugale»





**Vaibhab Chhabra**  
Fondateur, Maker's Asylum



**Richa Shrivastava**  
DG, Maker's Asylum



# 1er JOUR

early  
makers

em  
lyon  
business  
school



# 3e JOUR



© Maker's Asylum





**VISITE SUR LE TERRAIN**

**5e JOUR**





14e JOUR





# Teacher-Feels

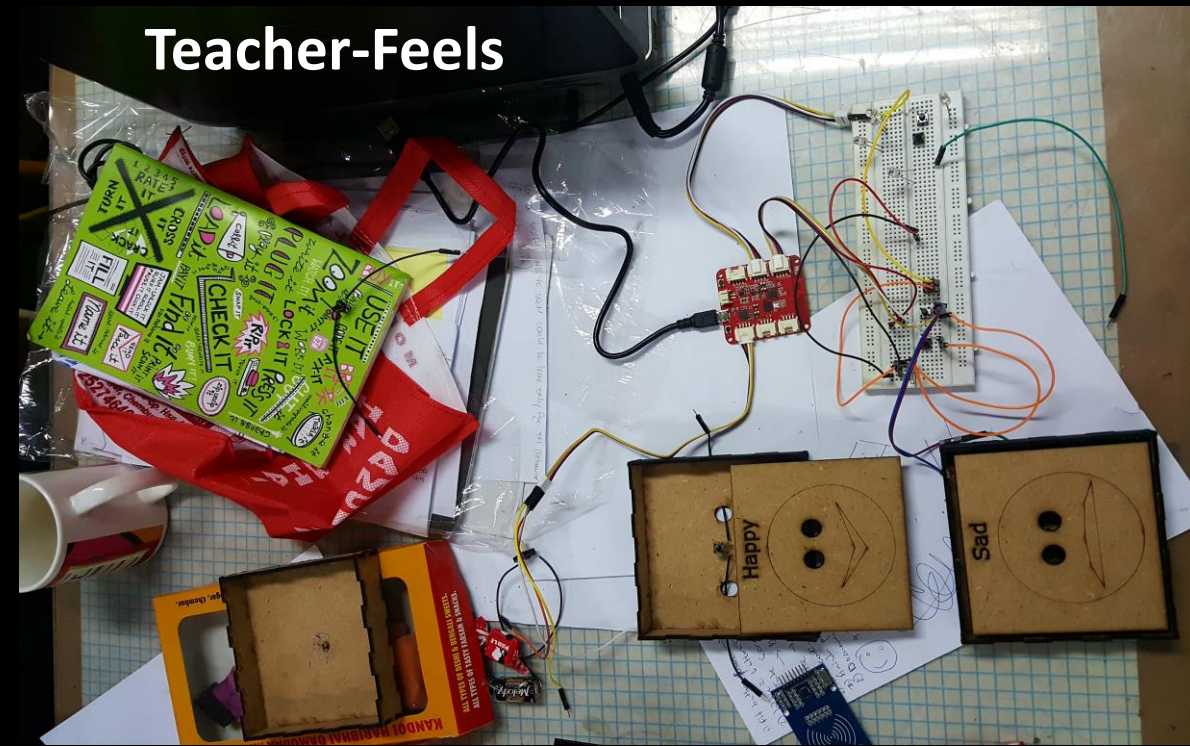

# सादा KIT

## PROBLEM

DECREASEING WATER-BORNE ILLNESS CAUSED BY OPEN-AIR DEFFECATION

## SOLUTION

USING सादा KIT PORTABLE TOILETS AND COMMUNITY COMPOST TO IMPROVE COMMUNITY HEALTH AND INCREASE ECONOMIC PROSPERITY.

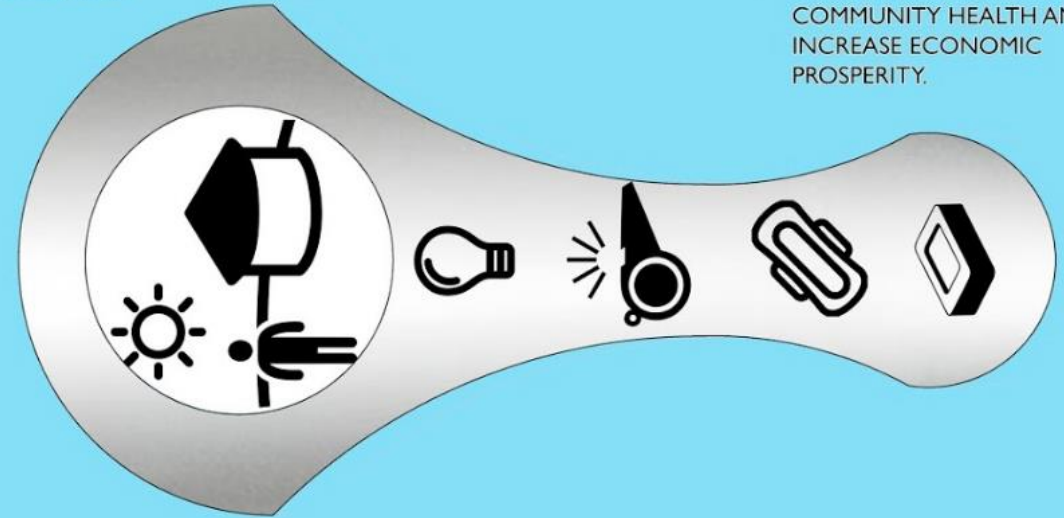

## The BAT



Using an Ultrasonic sensor to detect obstacles with an additional motor driver sheild and a Moveuino

Accurate detection of obstacles with a six axis feedback through vibrations in a 3m vicinity





**STEAM**  
SCHOOL 2017

Irina Blovir-Idler



# SDG SCHOOL

JULY 1<sup>ST</sup> - JULY 26<sup>TH</sup> 2019, PARIS



MAKER'S  
ASYLUM



# MAYOTTE: POINT DE RENCONTRE NORD—SUD POUR CO-CREER DES SOLUTIONS FRUGALES POUR “LES PROBLEMES SANS FRONTIERES”

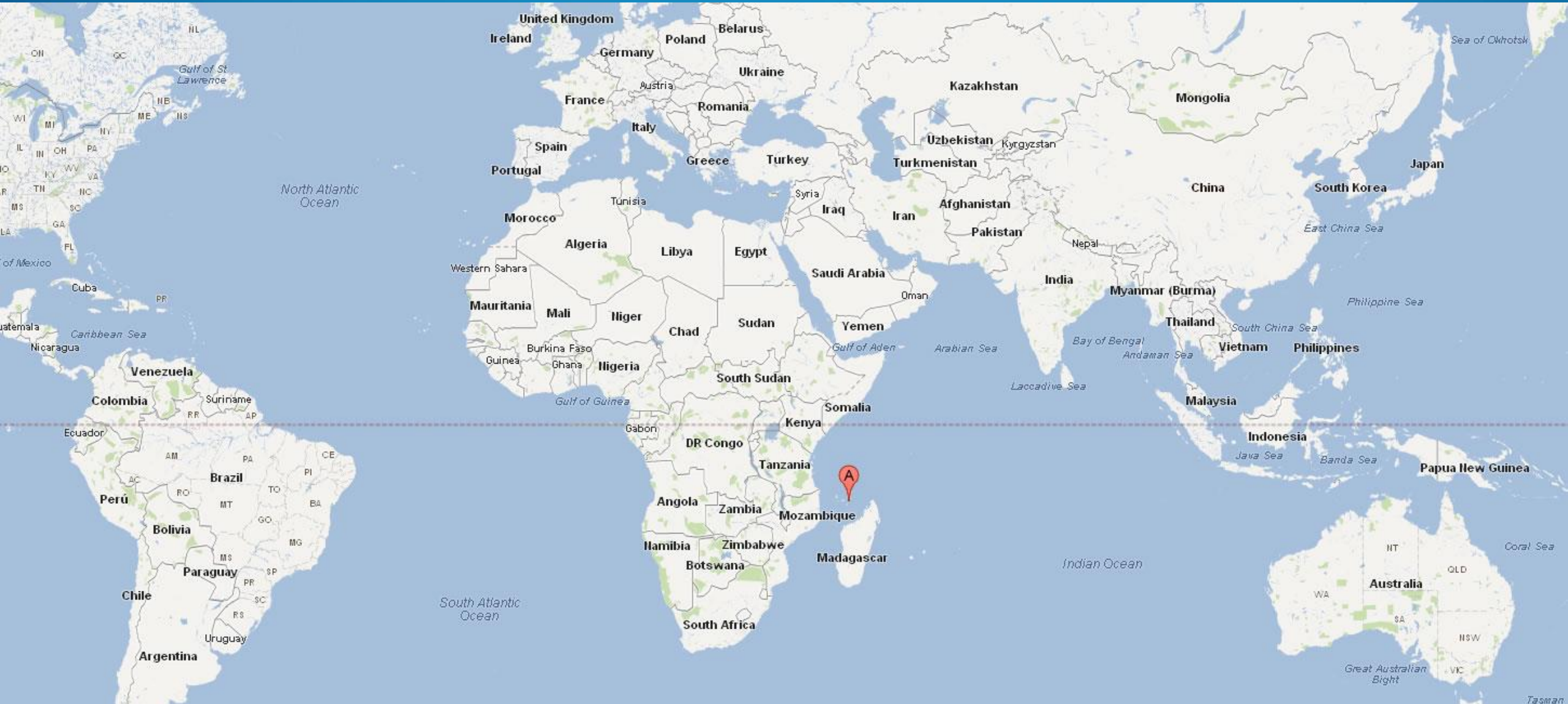



# DISCUSSION

**Mayotte peut devenir  
la pionnière de  
l'économie frugale**



# Le FMI revoit encore les prévisions de croissance mondiale

CROISSANCE DE L'ÉCONOMIE MONDIALE

**-4,9%**

à la baisse, au plus bas niveau  
depuis la Grande Dépression

# ECONOMIE FRUGALE

(Vivre Mieux En Optimisant Toutes Les Ressources)

Le Partage  
inter-  
entreprises

Production  
décentralisée

Triple  
Régénération



Citoyens et entrepreneurs engagés



# ECONOMIE FRUGALE

(Vivre Mieux En Optimisant Toutes Les Ressources)

Le Partage  
inter-  
entreprises

Production  
décentralisée

Triple  
Régénération



Citoyens et entrepreneurs engagés

# Mayotte peut construire des plateformes de **partage inter-entreprises**

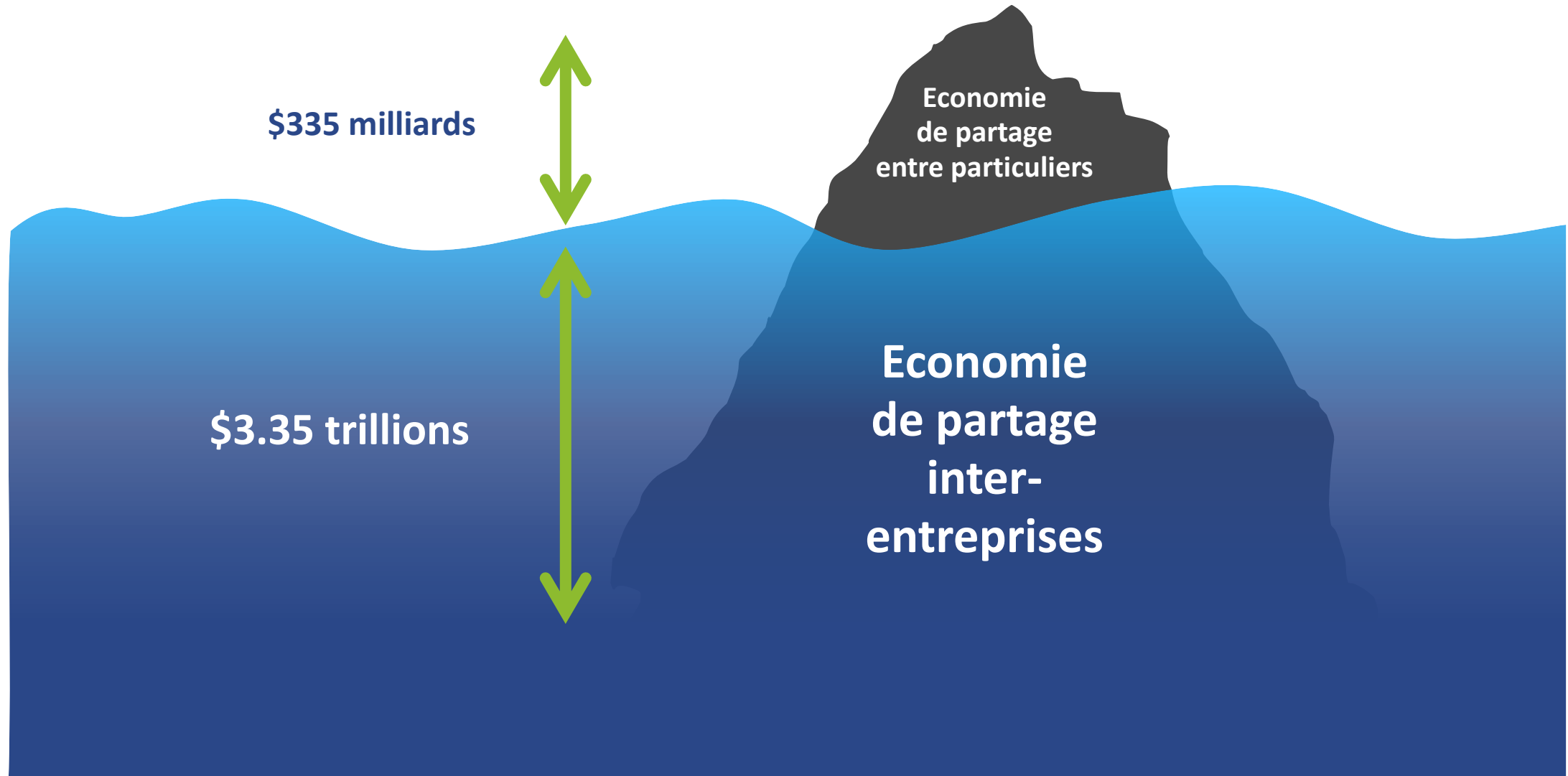



# Le Uber pour Agriculteurs





Land  
Preparation

Sowing /  
Transplanting



Crop  
Management



Post-Harvest  
Farm Management



Harvesting

- End To End
- On Demand
- Pay Per Use



[Donate](#)[COVID-19 Response](#)

# Make a Contribution!

No gift is too big or small.



PayPal







★ FEATURED

♥ MOST LIKED

👁 MOST VIEWED

✔ MOST ADOPTED

CLEAR ALL

Country

State

Language

Partner

Category

Subcategory

Topic

Subject

359 Collections Found

1 | 2 | 3 | 4 | 5 | 6 | 7 | 8 | 9 | 10 | ... | 30



7 Videos | 50:38

**Maternal, Child Health ...**

Madhya Pradesh | Neemadi  
By: RMNT

♥ 21 | 👁 22.7k | ✔ 934



5 Videos | 37:02

**Plant and Soil Nutrient...**

Telangana | Telugu  
By: SERP

♥ 145 | 👁 32k | ✔ 1,743



2 Videos | 13:50

**Housing Management**

Karnataka | Kannada  
By: BAIF

♥ 40 | 👁 13.9k | ✔ 0



6 Videos | 51:40

**Internal and External ...**

Karnataka | Kannada  
By: BAIF

♥ 131 | 👁 59.8k | ✔ 1,479



12 Videos | 02:12:51

**ZBNF Method of Padd...**

Andhra Pradesh | Telugu  
By: DOAG

♥ 956 | 👁 65.2k | ✔ 0



5 Videos | 01:02:20

**Paddy Cultivation Prac...**

Odisha | Odia  
By: CIMMYT

♥ 9 | 👁 5,245 | ✔ 28

[About Us](#) [Farmers](#) [Work With Us](#)



[Locations](#) [Careers](#) [News & Awards](#)

The world's largest platform for  
small-scale farmers





# The B2B Sharing Marketplace



**FLOOW2**  
world's reset button



Candidats

**Je cherche un emploi**

C'est par ici !

Entreprises

**J'ai besoin de talents**

C'est par là !

Partager  
des employés  
entre PME

## MUTUALISER LES COMPÉTENCES

Avec VENETIS, c'est :

- ✓ 23 ans d'expérience et de succès dans la mutualisation et le partage de compétences et de talents sur votre territoire
- ✓ Une présence de proximité sur 4 territoires : Nantes, Vannes-Ploërmel, Lorient-Auray et Saint-Nazaire et Guérande
- ✓ 32 métiers différents mutualisés et partagés dans les PME et TPE de votre territoire
- ✓ Des communautés d'échanges (RH, QHSE, Communication, Gestion)





# ECONOMIE FRUGALE

(Vivre Mieux En Optimisant Toutes Les Ressources)

Le Partage  
inter-  
entreprises

Production  
décentralisée

Triple  
Régénération



Citoyens et entrepreneurs engagés

# Pre-COVID-19 : chaines de valeur hyper-globalisées



1000s KMs

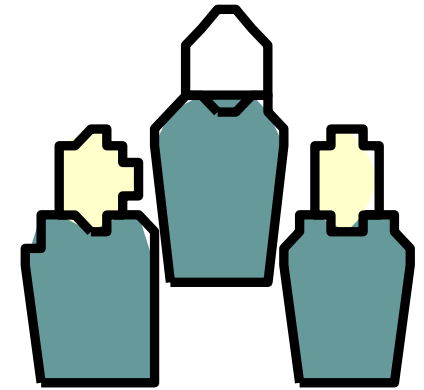

**GROSSES USINES  
EN CHINE**

**CONSOMMATEURS**

**VULNERABLES, PEU AGILES, ENERGIVORES ET POLLUANTES**



# Vers une production décentralisée

**P : Production**

**C : Consommation**

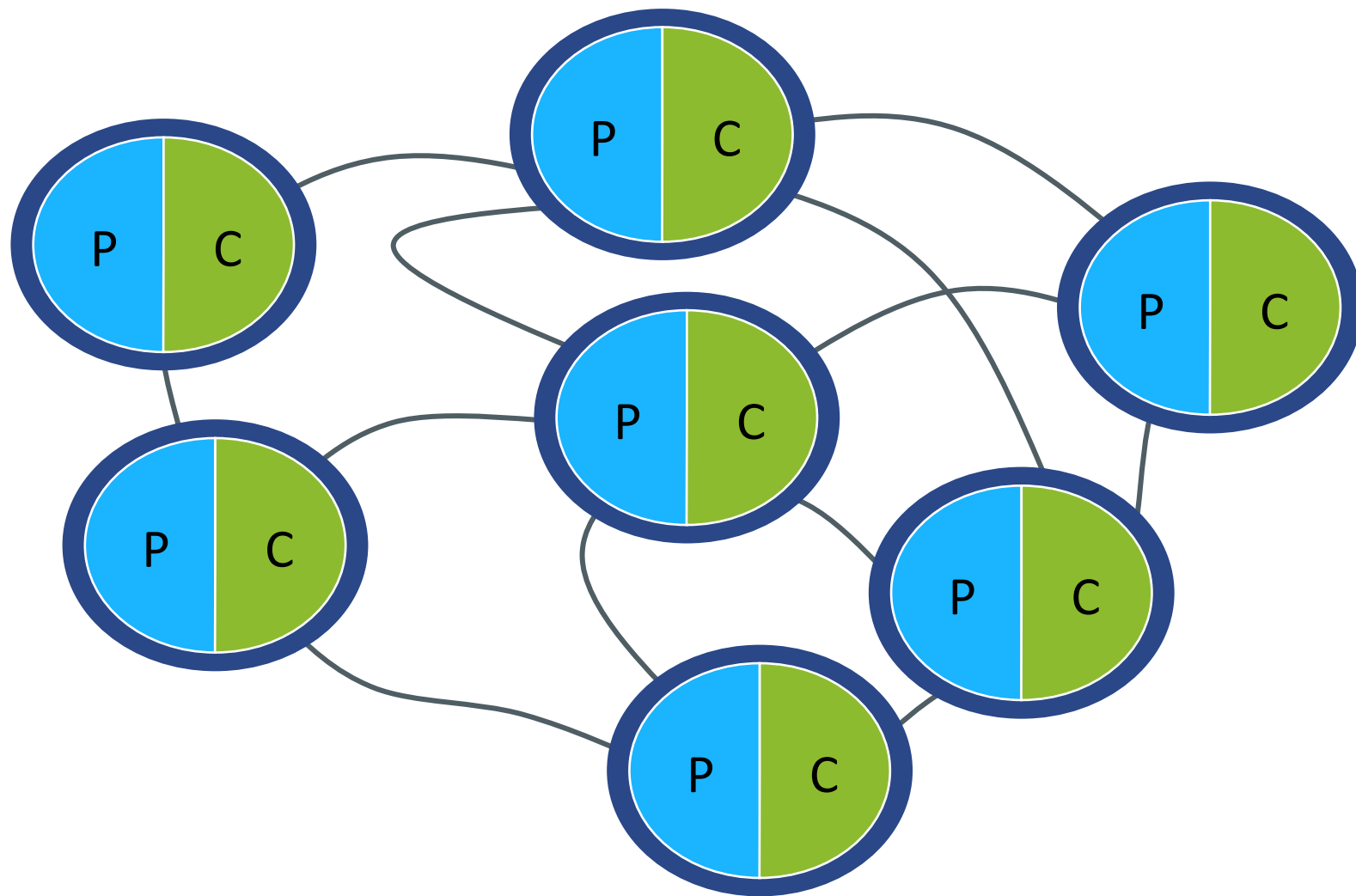

**INNOVATION THAT  
FUELS INDIA.  
INNOVATION THAT IS  
FUELLED BY INDIA.**

From helping businesses design and manufacture products better to grooming the next breed of makers, Imaginarium has been at the helm of the Advanced Manufacturing revolution.

OUR STORY



**L'impression 3D  
permet  
la « fabrication  
décentralisée »:**

- Petite quantité
- Grande variété
- Grande valeur



# When A Devastating Cyclone Plunged Towns Into Darkness, One Community Kept The Lights On

The Bay of Bengal community was able to avoid blackouts after Cyclone Amphan by relying on solar energy microgrids.





# Blue Lake Rancheria's Microgrid (California)







**Cassandra Delage**  
Fondatrice, Plast'if

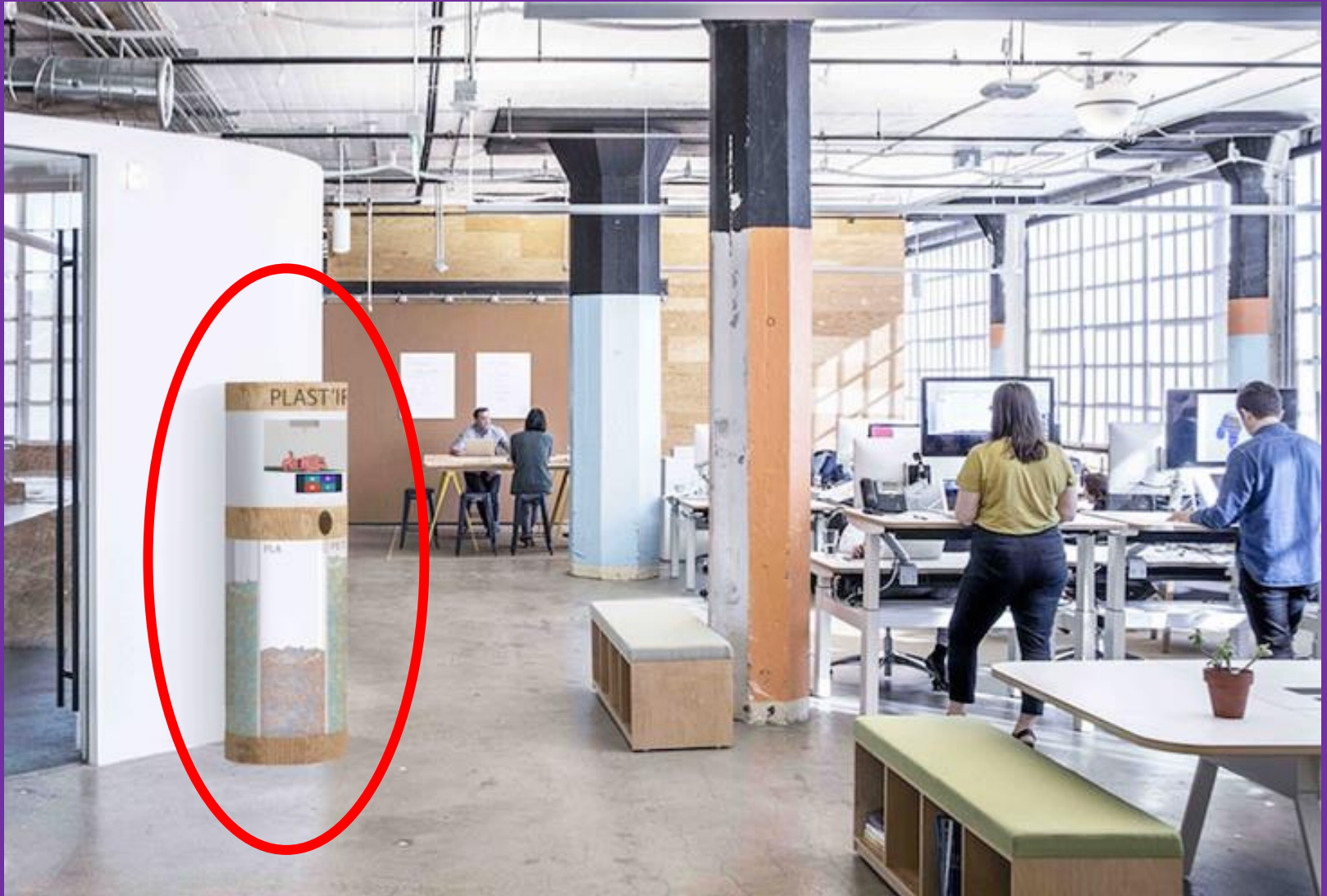

The Plast'if machine recycles all plastic waste of your employees and allows them to 3D print new objects from that waste.





# LE PARIS DU 1/4 HEURE

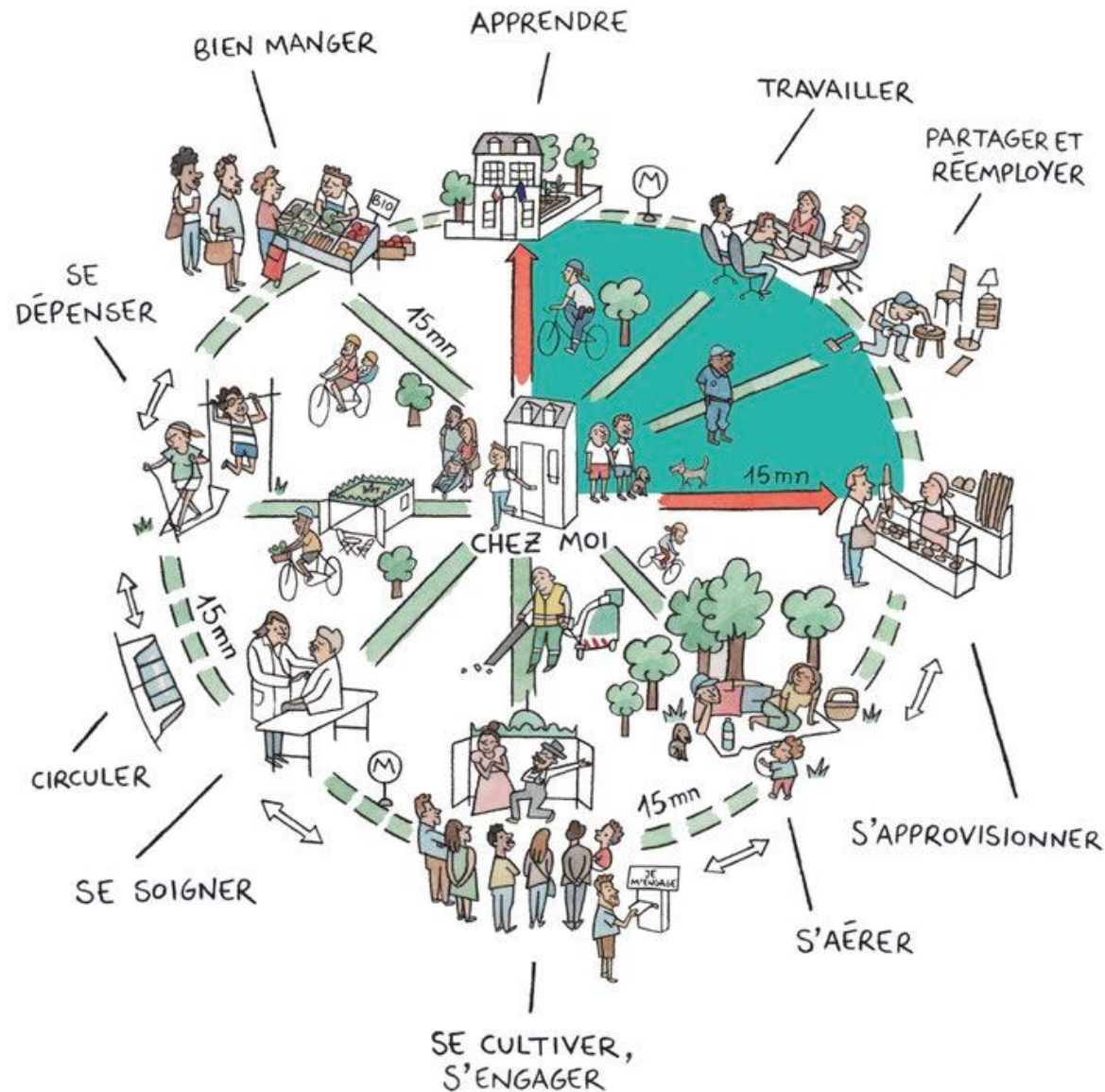

## Le Paris du 1/4 heure

# ECONOMIE FRUGALE

(Vivre Mieux En Optimisant Toutes Les Ressources)

Triple  
Régénération

Citoyens et entrepreneurs engagés



**INDIVIDUS**



**Triple  
Régénération**



**LIEUX  
(Communautés)**



**PLANETE**



# L'AGRICULTURE RÉGÉNÉRATRICE

RESPECTE  
LE BIEN-ÊTRE  
DES ANIMAUX



RESTAURE LES SOLS POUR PRÉSERVER  
L'EAU ET LA BIODIVERSITÉ ET ATTÉNUER  
LE CHANGEMENT CLIMATIQUE

PROMEUT LA  
QUALITÉ DE VIE  
DES AGRICULTEURS





# Loos-en-Gohelle, Hauts-de-France

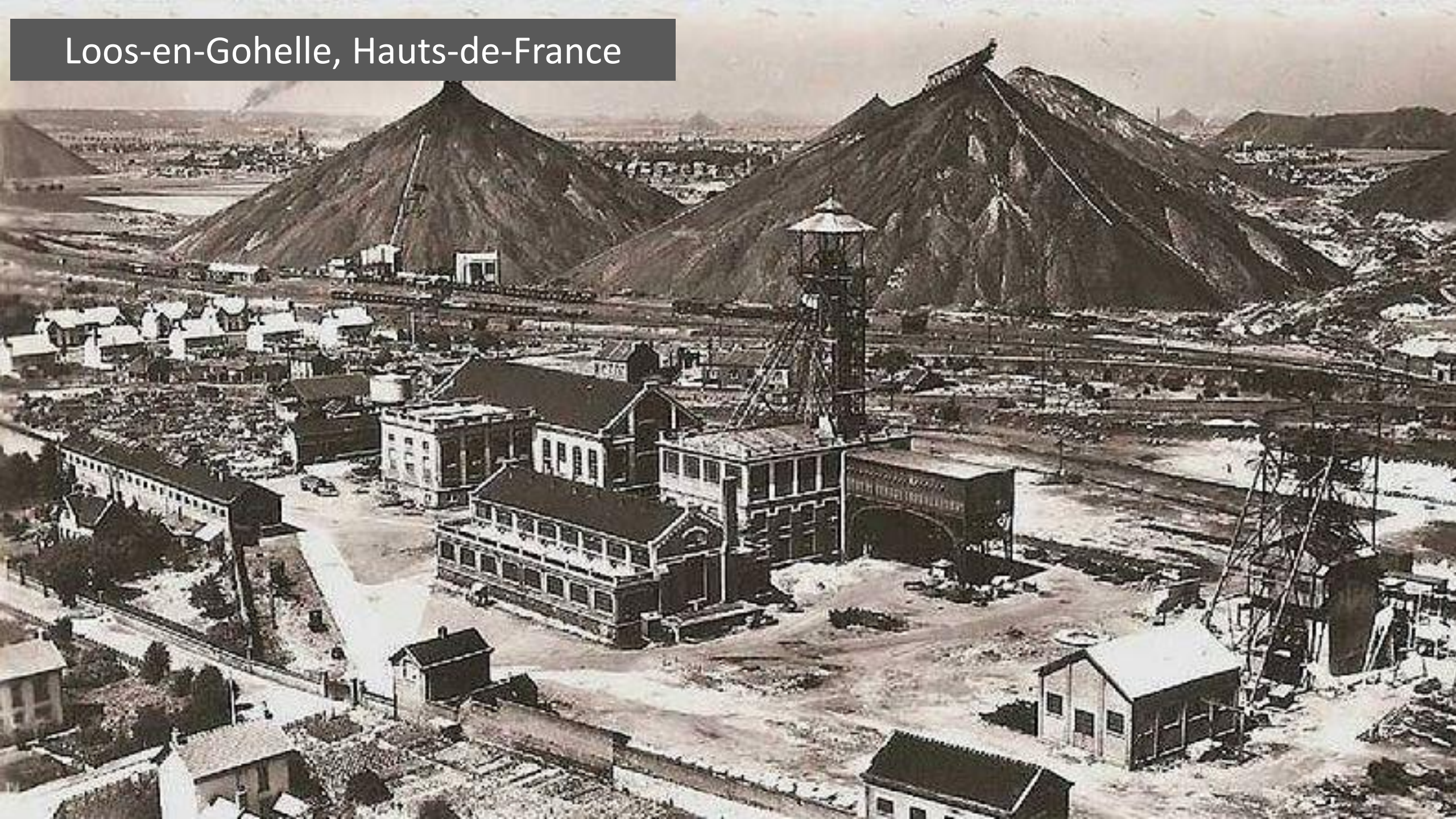





Jean-François CARON, Maire



LOOS EN GOHELLE

Bassin minier  
Nord-Pas de Calais  
Patrimoine mondial  
de l'UNESCO

CONSEIL NATIONAL  
Le Fleurie  
ET VILLAGE







**Je n'ai pas les  
reponses.  
Pouvez-vous  
m'aider ?**





Mairie de Loos-en-Gohelle





## Transition à l'agriculture bio et circuits courts





# Recycler le marc de café



# Pépinière de « green startups » (1<sup>ère</sup> en Europe)





Le moteur d'une économie extractive



Le moteur d'une économie régénératrice





Novembre 2018



**POUR RECAPITULER**

# Le FMI revoit encore les prévisions de croissance mondiale

CROISSANCE DE L'ÉCONOMIE MONDIALE

**-4,9%**

à la baisse, au plus bas niveau  
depuis la Grande Dépression



# L'innovation frugale: Faire mieux avec moins

↑ **VALEUR(S)**

- Economique
- Sociale
- Ecologique

↓ **RESSOURCES**

- Capital
- Energie
- Temps

# LES 6 PRINCIPES DE L'INNOVATION FRUGALE





# Mayotte: pionnière d'une économie frugale

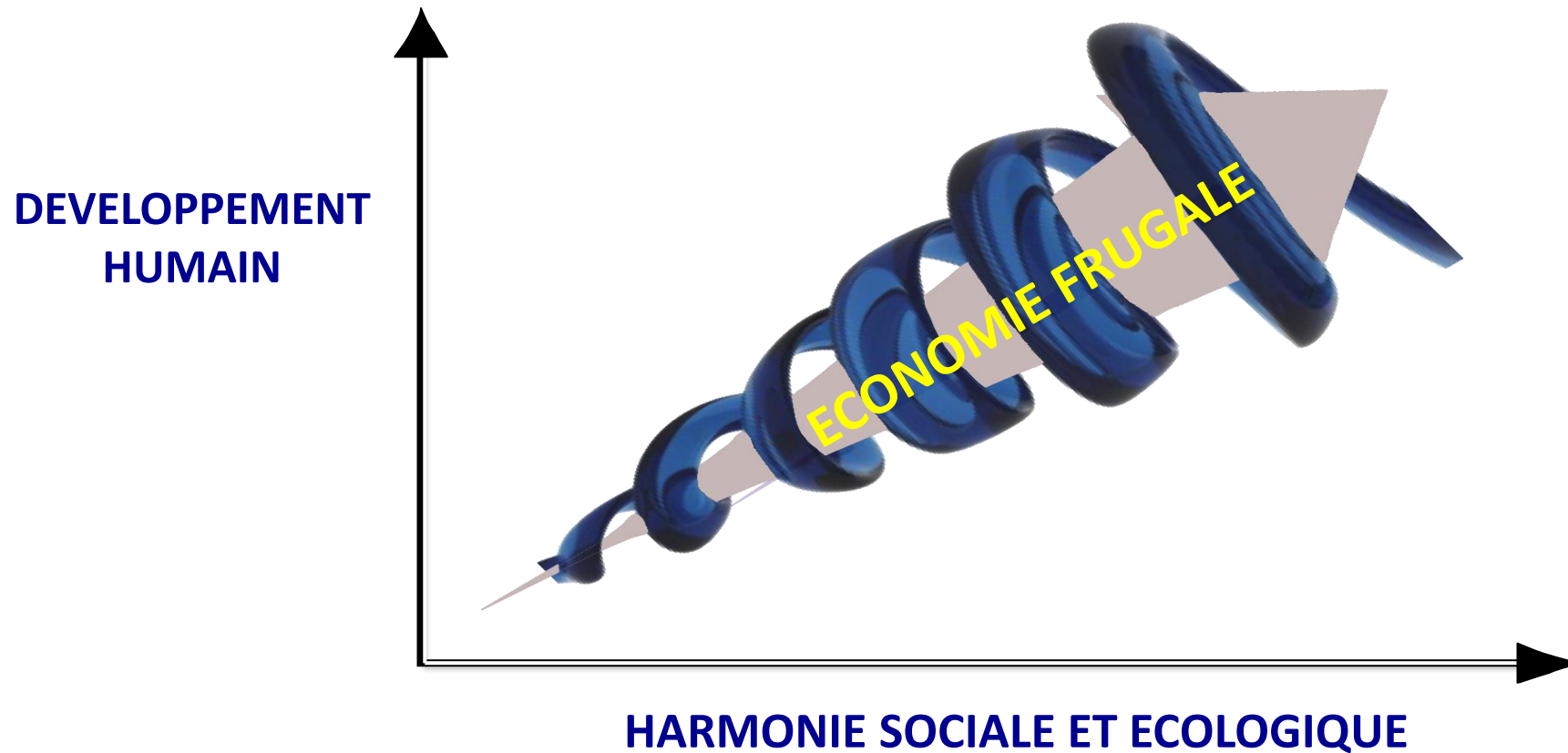

# ECONOMIE FRUGALE

(Vivre Mieux En Optimisant Toutes Les Ressources)

Le Partage  
inter-  
entreprises

Production  
décentralisée

Triple  
Régénération



Citoyens et entrepreneurs engagés





## RESSOURCES TANGIBLES:

- Argent
- Matériel
- Personnel



## RESSOURCES INTANGIBLES

- Ingéniosité
- Empathie
- Résilience
- Capital intellectuel
- Capital culturel
- Technologies existantes
- Diversité des talents

# Libérez le **GENIUS LOCI** (ingéniosité) de Mayotte





# Discussion

